MIC 1800

1/8 DIN MICROBASED CONTROLLER

OPERATORS
MANUAL
FORM 3539
EDITION 1
© JAN. 1995
PRICE \$10.00



CIRCULAR CHART RECORDERS • STRIP CHART RECORDERS • DATA ACQUISITION SYSTEMS
DATALOGGERS • ANALOG AND MICROBASED CONTROLLERS
MECHANICAL RECORDERS AND CONTROLLERS
PARTLOW CORPORATION • 2 CAMPION ROAD • NEW HARTFORD, NY 13413 USA
1-800-866-6659 • 315-797-2222 • FAX 315-797-0403

Information in this installation, wiring, and operation manual is subject to change without notice. One manual is provided with each instrument at the time of shipment. Extra copies are available at the price published on the front cover.

Copyright © Dec. 1994, The Partlow Corporation, all rights reserved. No part of this publication may be reproduced, transmitted, transcribed or stored in a retrieval system, or translated into any language in any form by any means without the written permission of the Partlow Corporation.

This is the First Edition of the MIC 1800 manual. It was written and produced entirely on a desk-top-publishing system. Disk versions are available by written request to the Partlow Publications Department.

We are glad you decided to open this manual. It is written so that you can take full advantage of the features of your new MIC 1800 process controller.

NOTE:

It is strongly recommended that Partlow equipped applications incorporate a high or low limit protective device which will shut down the equipment at a preset process condition in order to preclude possible damage to property or products.

Table of Contents

Section 1 - General	Page
1.1 Product Description	5
Section 2 - Installation & Wiring	
2.1 Installation & Wiring	7
2.2 Preparations for Wiring	9
2.3 Input Connections	16
2.4 Output Connections	18
Section 3 - Configuration & Operation	
3.1 Operation	21
3.2 Configuration	26
3.3 Pre-Tune Mode	33
3.4 Auto-Tune Mode	33
3.5 Manual Tuning Method	34
Section 4 - Control Capability	
4.1 Control Capability	36
4.2 Control Responses	36
4.3 Direct/Reverse Operation of Control Outputs	37
4.4 On-Off Control	37
4.5 Time Proportioning Control	37
4.6 Current Proportioning Control	38
4.7 Setpoint Adjustments	39
Appendices	
A - Glossary of Terms	40
Figure A-1 Proportional Band & Deadband/Overlap	50
B - Board Layout - Jumper positioning	51
Figure B-1 PCB Positions	51
Figure B-2 Output 2/Output 3 Removal	52
Figure B-3 CPU PWA	53
Figure B-4 PSU PWA with Relay or SSR Out.1	54
Figure B-5 PSU PWA with DC Output 1	55
C - Hardware Definition Code	56
D - Input Range Codes	58
E - Specifications	60
F - Model Number Hardware Matrix	66

Figures & Tables

Figure 1-1	Controller Display Illustration	6
Figure 2-1	Panel Cut-Out Dimensions	7
Figure 2-2	Main Dimensions	8
Figure 2-3	Panel Mounting the controller	8
Figure 2-4	Noise Suppression	11
Figure 2-5	Noise Suppression	12
Figure 2-6	Wiring Label	15
Figure 2-7	AC Power	16
Figure 2-8	Thermocouple Input	16
Figure 2-9	RTD Input	16
Figure 2-10	Volt, mV mADC Input	17
Figure 2-11	Remote Digital Connections	17
Figure 2-12	Relay Output 1	18
Figure 2-13	SSR Driver Output 1	18
Figure 2-14	mADC Output 1	18
Figure 2-15	Relay Output 2	19
Figure 2-16	SSR Driver Output 2	19
Figure 2-17	mADC Output 2	19
Figure 2-18	Relay Output 3	20
Figure 2-19	SSR Driver Output 3	20
Figure 2-20	mADC Output 3	20
Figure 4-1	Proportional Bandwidth Effect on Output	38
Table 3-1	Enable Mode Configuration Procedures	26
Table 3-2	Program Mode Configuration Procedures	27
Table 3-3	Tune Mode Configuration Procedures	29

Product Description 1.1

1.1.1 GENERAL

This instrument is a microprocessor based single loop controller capable of measuring, displaying and controlling temperature, pressure, flow, and level from a variety of inputs. Most outputs are easily tuned using the instrument Pre-Tune and Auto-Tune functions.

Control functions, alarm settings and other parameters are easily entered through the front keypad. E² Technology (100 year life) protects against data loss during AC power outages.

The input is user configurable to directly connect to either thermocouple, RTD, mVDC, VDC or mADC inputs. The instrument can operate from a 90-264 VAC, 50/60 HZ power supply.

1.1.2 DISPLAYS

Each instrument is provided with dual displays and status indicators as shown in Figure 1-1. The upper display displays the value of the process variable. The lower display displays the setpoint value. Status indication is as shown, see Figure 1-1, page 6.

1.1.3 CONTROL

The instrument can be programmed for on-off, time proportioning, or current proportioning control implementations depending on the model number. A second control output is an available option. Proportional control implementations are provided with fully programmable PID parameters.

1.1.4 ALARMS

Alarm indication is standard on all instruments. Up to two alarm outputs are possible. Alarm type may be set as Process Direct or Reverse (high or low), Deviation Direct or Reverse (above or below setpoint), Deviation Band Type (closed or open within band), or Loop Reverse or Direct. Alarm status is indicated by LED.

FIGURE 1-1
Keys and Indicators

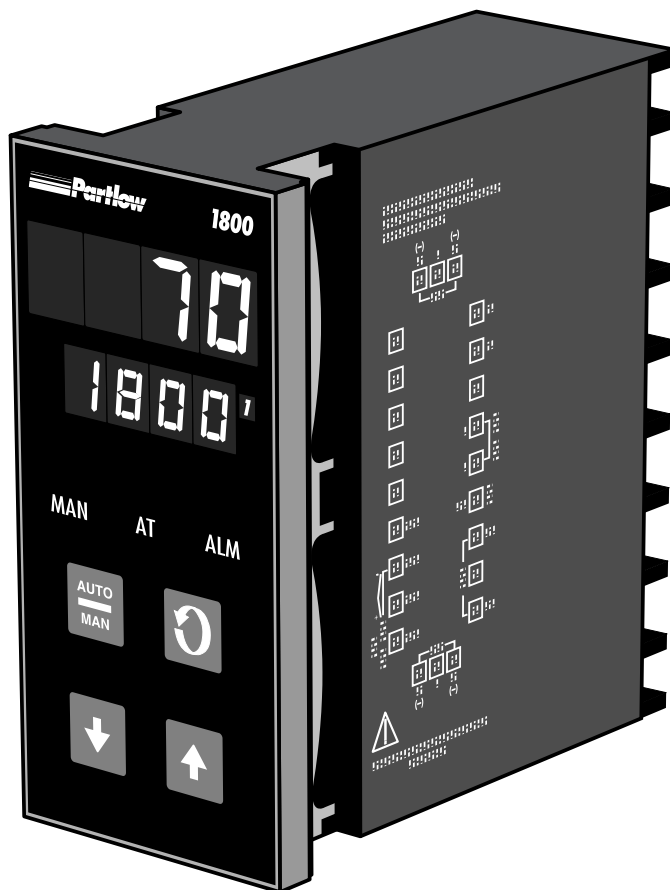

1.1.5 PROCESS VARIABLE/SETPOINT VALUE RE-TRANSMISSION OUTPUT

If the instrument is specified with this option, this output may be scaled over any desired range and re-transmitted.

Installation and Wiring 2.1

Electrical code requirements and safety standards should be observed and installation performed by qualified personnel.

The electronic components of the instrument may be removed from the housing during installation. To remove the components, grip the side edges of the front panel and pull the instrument forward. During re-installation, the vertically mounted circuit boards should be properly aligned in the housing.,

Ensure that the instrument is correctly orientated. A stop will operate if an attempt is made to insert the instrument incorrectly.

Recommended panel opening sizes are illustrated in Figure 2-1. After the opening is properly cut, insert the instrument into the panel opening. Ensure that the panel gasket is not distorted and that the instrument is positioned squarely against the panel. Slide the mounting clamp into place on the instrument (see Figure 2-3, page 8) and push it forward until it is firmly in contact with the rear face of the mounting panel.

Note: *The mounting clamp tongues may engage either on the sides or the top/bottom of the instrument housing. Therefore, when installing several instruments side-by-side in one cut out, use the ratchets on the top/bottom faces.*

FIGURE 2-1
Panel Cut-Out Dimensions

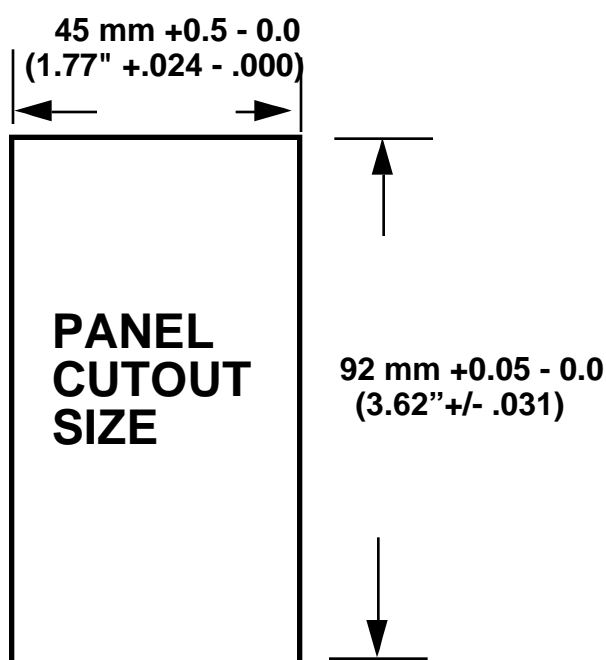

FIGURE 2-2
Main Dimensions

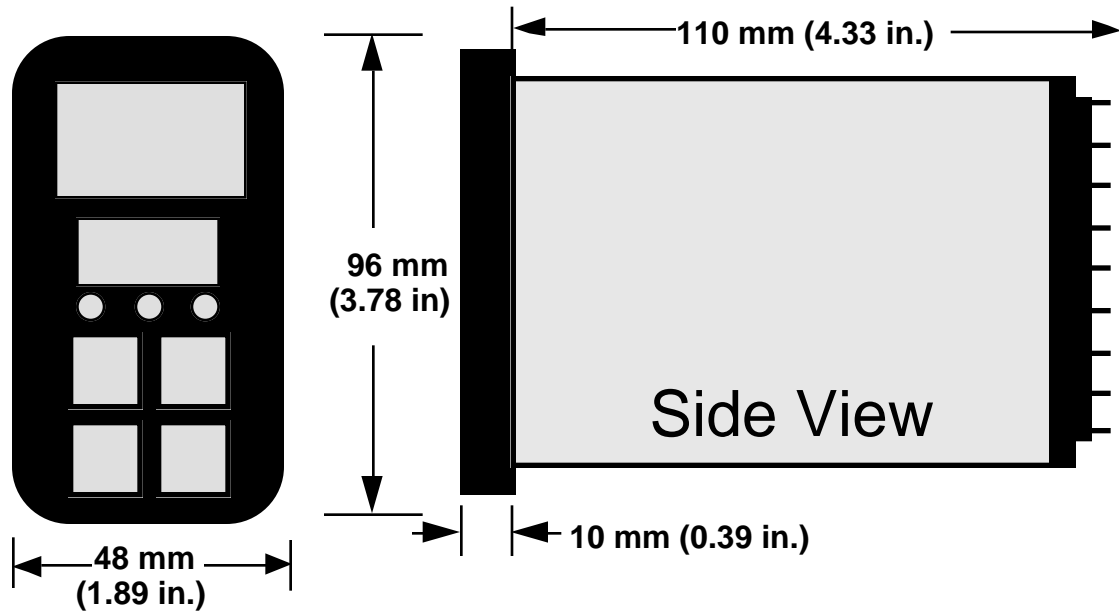
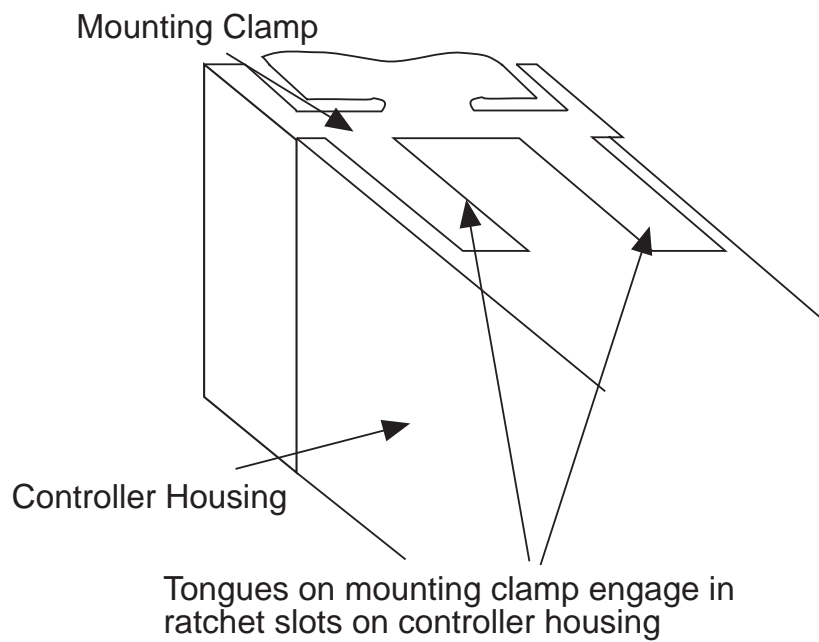

FIGURE 2-3
Panel Mounting the Controller



Preparation for Wiring 2.2

2.2.1 WIRING GUIDELINES

Electrical noise is a phenomenon typical of industrial environments. The following are guidelines that must be followed to minimize the effect of noise upon any instrumentation.

2.2.1.1 INSTALLATION CONSIDERATIONS

Listed below are some of the common sources of electrical noise in the industrial environment:

- Ignition Transformers
- Arc Welders
- Mechanical contact relay(s)
- Solenoids

Before using any instrument near the device listed, the instructions below should be followed:

1. If the instrument is to be mounted in the same panel as any of the listed devices, separate them by the largest distance possible. For maximum electrical noise reduction, the noise generating devices should be mounted in a separate enclosure.
2. If possible, eliminate mechanical contact relay(s) and replace with solid state relays. If a mechanical relay being powered by an instrument output device cannot be replaced, a solid state relay can be used to isolate the instrument.
3. A separate isolation transformer to feed only instrumentation should be considered. The transformer can isolate the instrument from noise found on the AC power input.
4. If the instrument is being installed on existing equipment, the wiring in the area should be checked to insure that good wiring practices have been followed.

2.2.1.2 AC POWER WIRING

Neutral (For 115 VAC)

It is good practice to assure that the AC neutral is at or near ground potential. To verify this, a voltmeter check between neutral and ground should be done. On the AC range, the reading should not be more than 50 millivolts. If it is greater than this amount, the secondary of this AC transformer supplying the instrument should be checked by an electrician. A proper neutral will help ensure maximum performance from the instrument.

2.2.1.3 WIRE ISOLATION

Four voltage levels of input and output wiring may be used with the unit:

- Analog input or output (i.e. thermocouple, RTD, VDC, mVDC, or mADC)
- SPDT Relays
- SSR driver outputs
- AC power

The only wires that should run together are those of the same category. If they need to be run parallel with any of the other lines, maintain a minimum 6 inch space between the wires. If wires must cross each other, do so at 90 degrees. This will minimize the contact with each other and reduces “cross talk”. “Cross Talk” is due to the EMF (Electro Magnetic Flux) emitted by a wire as current passes through it. This EMF can be picked up by other wires running in the same bundle or conduit.

In applications where a High Voltage Transformer is used (i.e. ignition systems) the secondary of the transformer should be isolated from all other cables.

This instrument has been designed to operate in noisy environments, however, in some cases even with proper wiring it may be necessary to suppress the noise at its source.

2.2.1.4 USE OF SHIELDED CABLE

Shielded cable helps eliminate electrical noise being induced on the wires. All analog signals should be run with shielded cable. Connection lead length should be kept as short as possible, keeping the wires protected by the shielding. The shield should be grounded at one end only. The preferred grounding location is the sensor, transmitter or transducer.

2.2.1.5 NOISE SUPPRESSION AT THE SOURCE

Usually when good wiring practices are followed no further noise protection is necessary. Sometimes in severe electrical environments, the amount of noise is so great that it has to be suppressed at the source. Many manufacturers of relays, contactors, etc. supply “surge suppressors” which mount on the noise source.

For those devices that do not have surge suppressors supplied, RC (resistance-capacitance) networks and/or MOV (metal oxide varistors) may be added.

Inductive Coils - MOV's are recommended for transient suppression in inductive coils connected in parallel and as close as possible to the coil. See Figure 2-4. Additional protection may be provided by adding an RC network across the MOV.

FIGURE 2-4

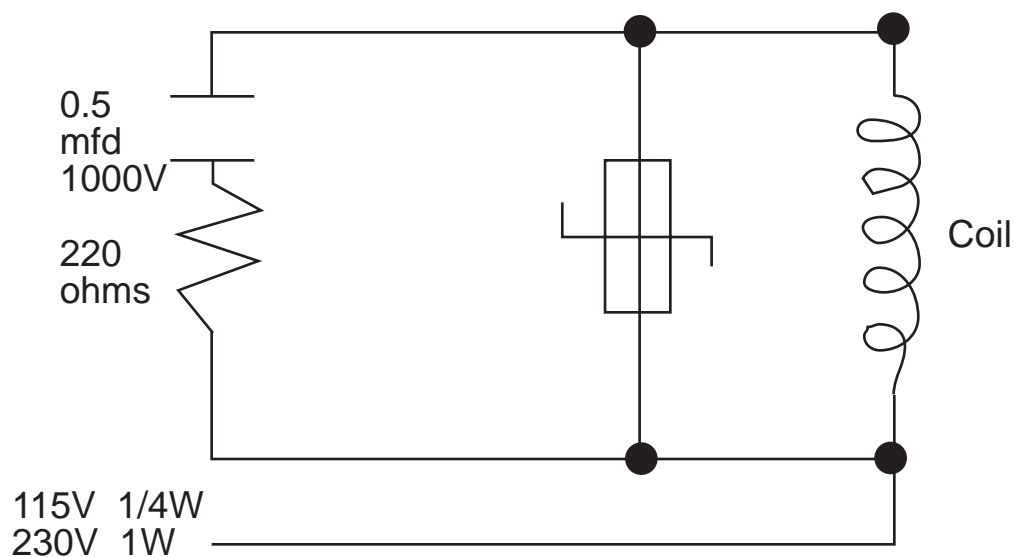

Contacts - Arcing may occur across contacts when the contact opens and closes. This results in electrical noise as well as damage to the contacts. Connecting a RC network properly sized can eliminate this arc.

For circuits up to 3 amps, a combination of a 47 ohm resistor and 0.1 microfarad capacitor (1000 volts) is recommended. For circuits from 3 to 5 amps, connect 2 of these in parallel. See Figure 2-5, page 12.

FIGURE 2-5

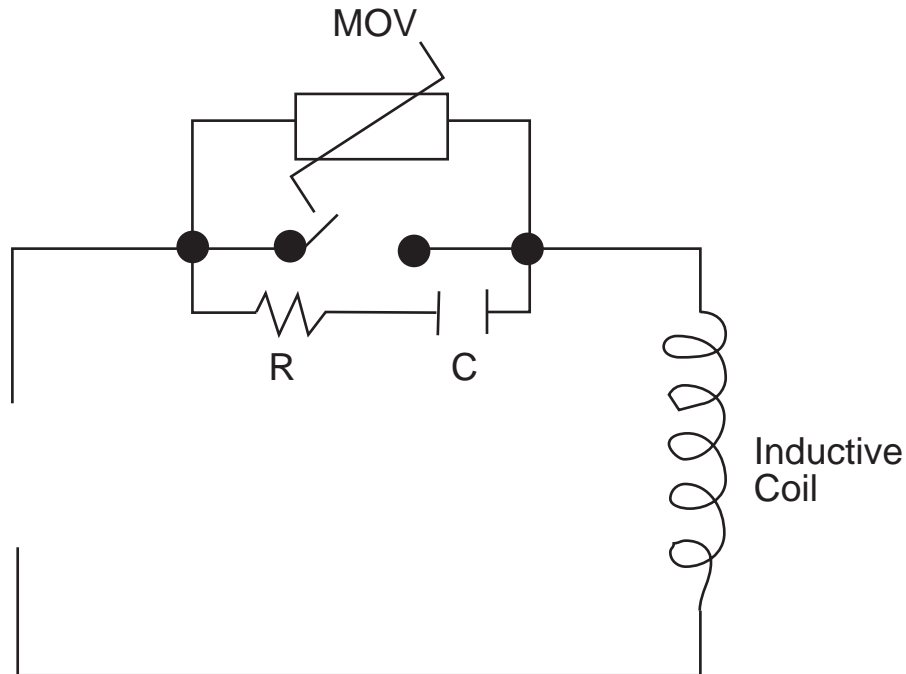

2.2.2 SENSOR PLACEMENT (Thermocouple or RTD)

Two wire RTD's should be used only with lead lengths less than 10 feet.

If the temperature probe is to be subjected to corrosive or abrasive conditions, it should be protected by the appropriate thermowell. The probe should be positioned to reflect true process temperature:

In liquid media - the most agitated area

In air - the best circulated area

THERMOCOUPLE LEAD RESISTANCE

Thermocouple lead length can affect instrument accuracy since the size (gauge) and the length of the wire affect lead resistance.

To determine the temperature error resulting from the lead length resistance, use the following equation:

$$T_{err} = T_{Le} * L \quad \text{where; } \quad T_{Le} = \text{value from appropriate table (see next page)}$$

$L = \text{length of leadwire in thousands of feet}$

TABLE 1

Temperature error in °C per 1000 feet of leadwire									
AWG NO.	Thermocouple Type:								
	J	K	T	R	S	E	B	N	C
10	.34	.85	.38	1.02	1.06	.58	7.00	1.47	1.26
12	.54	1.34	.61	1.65	1.65	.91	11.00	2.34	2.03
14	.87	2.15	.97	2.67	2.65	1.46	17.50	3.72	3.19
16	1.37	3.38	1.54	4.15	4.18	2.30	27.75	5.91	5.05
18	2.22	5.50	2.50	6.76	6.82	3.73	44.25	9.40	8.13
20	3.57	8.62	3.92	10.80	10.88	5.89	70.50	14.94	12.91
24	8.78	21.91	9.91	27.16	27.29	14.83	178.25	37.80	32.64

TABLE 2

Temperature error in °F per 1000 feet of leadwire									
AWG NO.	Thermocouple Type:								
	J	K	T	R	S	E	B	N	C
10	.61	1.54	.69	1.84	1.91	1.04	12.60	2.65	2.27
12	.97	2.41	1.09	2.97	2.96	1.64	19.80	4.21	3.66
14	1.57	3.86	1.75	4.81	4.76	2.63	31.50	6.69	5.74
16	2.47	6.09	2.77	7.47	7.52	4.14	49.95	10.64	9.10
18	4.00	9.90	4.50	12.17	12.28	6.72	79.95	10.64	9.10
20	6.43	15.51	7.06	19.43	19.59	10.61	126.90	26.89	23.24
24	15.80	39.44	17.83	48.89	49.13	26.70	320.85	68.03	58.75

Example:

A 1/16 DIN unit is to be located in a control room 660 feet away from the process. Using 16 AWG, type J thermocouple, how much error is induced?

$$T_{err} = TLe * L$$

$$TLe = 2.47 \text{ (°F.1000 ft) from Table 2}$$

$$T_{err} = 2.47 \text{ (°F/1000 ft)} * 660 \text{ ft}$$

$$T_{err} = 1.6^\circ\text{F}$$

RTD LEAD RESISTANCE

RTD lead length can affect instrument accuracy, since the size (gauge) and length of the wire affect lead resistance.

To determine the temperature error resulting from the lead length resistance, use the following equation:

$$T_{err} = T_{Le} * L \quad \text{where;} \quad T_{Le} = \text{value from Table 3 if 3 wire RTD or Table 4 if 2 wire RTD}$$

$L = \text{length of lead wire in thousands of feet}$

TABLE 3 3 Wire RTD

AWG NO.	Error °C	Error °F
10	± 0.04	± 0.07
12	± 0.07	± 0.11
14	± 0.10	± 0.18
16	± 0.16	± 0.29
18	± 0.26	± 0.46
20	± 0.41	± 0.73
24	± 0.65	± 1.17

TABLE 4 2 Wire RTD

AWG NO.	Error °C	Error °F
10	± 5.32	± 9.31
12	± 9.31	± 14.6
14	± 13.3	± 23.9
16	± 21.3	± 38.6
18	± 34.6	± 61.2
20	± 54.5	± 97.1
24	± 86.5	± 155.6

Example:

An application uses 2000 feet of 18 AWG copper lead wire for a 3 wire RTD sensor. What is the worst case error due to the leadwire length?

$$T_{err} = T_{Le} * L$$

$T_{Le} = \pm .46 \text{ (}^\circ\text{F/1000 ft) from Table 3}$

$$T_{err} = \pm .46 \text{ (}^\circ\text{F/1000 ft) * 2000 ft}$$

$$T_{err} = \pm 0.92^\circ\text{F}$$

FIGURE 2-6
Wiring Label

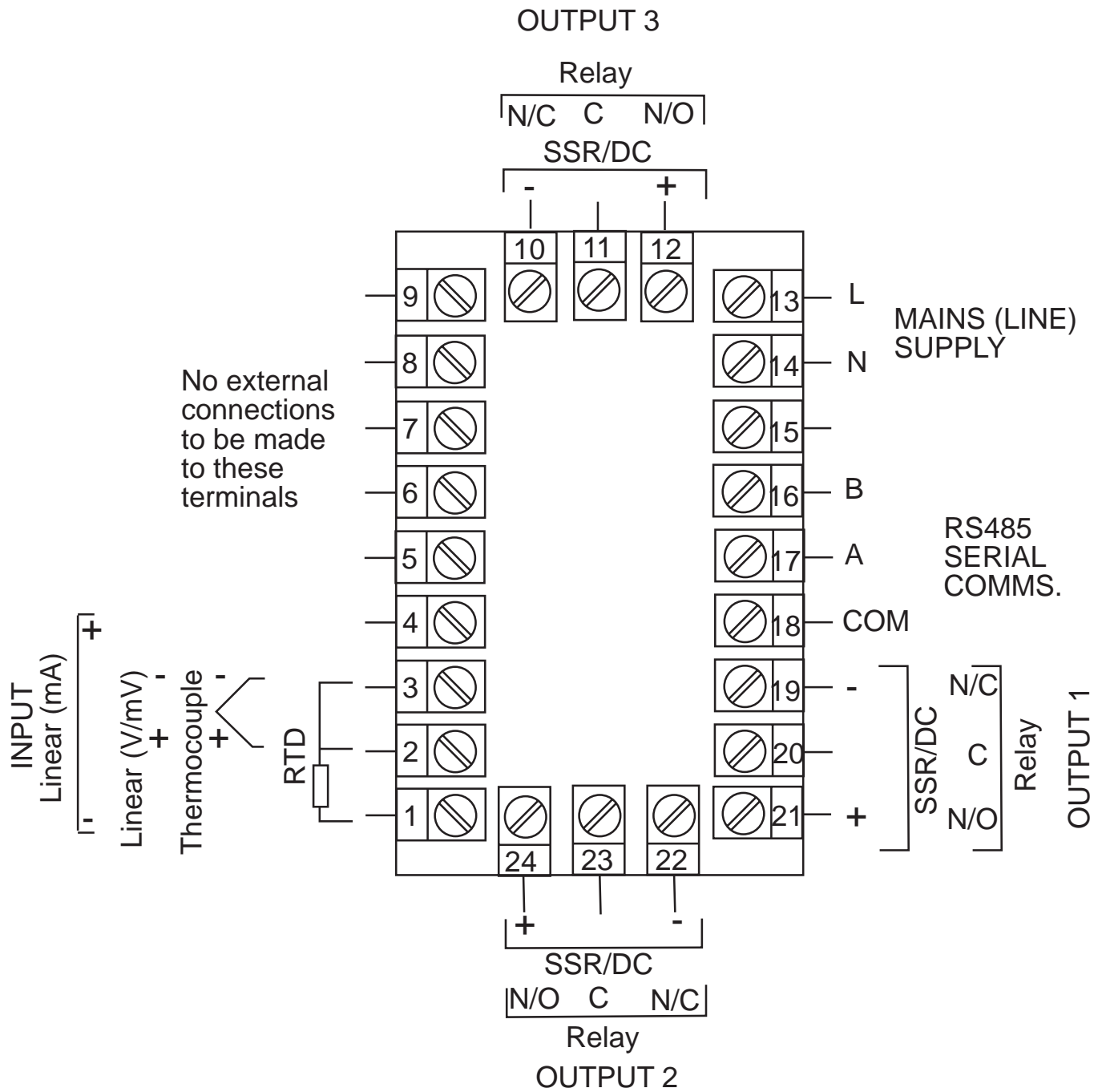

Input Connections 2.3

In general, all wiring connections are made to the instrument after it is installed. Avoid Electrical Shock. AC power wiring must not be connected to the source distribution panel until all wiring connection procedures are completed.

FIGURE 2-7

AC Power

Connect the line voltage, hot and neutral, to terminals 13 and 14 respectively as illustrated below.

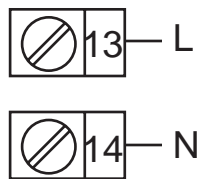

FIGURE 2-8

Thermocouple (T/C) Input

Make thermocouple connections as illustrated below. Connect the positive leg of the thermocouple to terminal 2 and the negative leg to terminal 3.

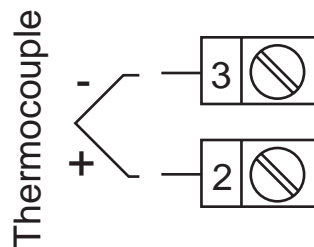

FIGURE 2-9

RTD Input

Make RTD connections as illustrated below. For a three wire RTD, connect the resistive leg of the RTD to terminal 1 and the common legs to terminals 2 and 3. For a two wire RTD, connect one leg to terminal 2 and the other leg to terminal 3 as shown below. A jumper wire supplied by the customer must be installed between terminals 2 and 3. Input conditioning jumper must be positioned correctly (see Appendix B) and Hardware Definition Code must be correct (see Appendix C).

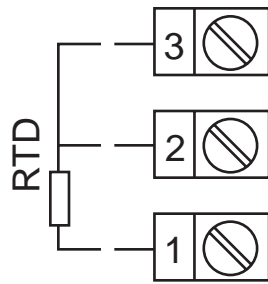

FIGURE 2-10

Volt, mV Input

Make volt and millivolt connections as shown below. Terminal 2 is positive and terminal 3 is negative. Input conditioning jumper must be positioned correctly (see Appendix B) and Hardware Definition Code must be correct (see Appendix C).

mADC Input

Make mADC connections as shown below. Terminal 3 is positive and terminal 1 is negative. Input conditioning jumper must be positioned correctly (see Appendix B) and Hardware Definition Code must be correct (see Appendix C).

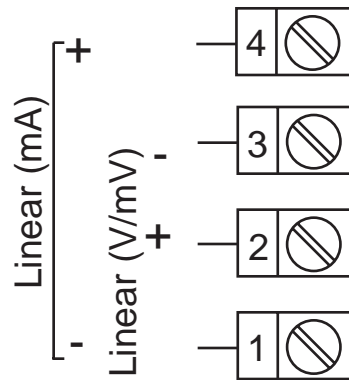
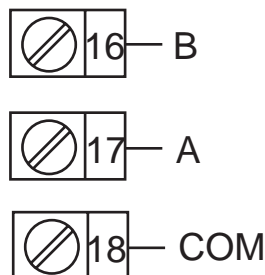

FIGURE 2-11

Remote Digital Communications - RS485

Make digital communication connections as illustrated below.



Output Connections 2.4

FIGURE 2-12

Relay Output 1

Connections are made to Output 1 relay as illustrated below. The contacts are rated at 2 amp resistive, 120/240 VAC.

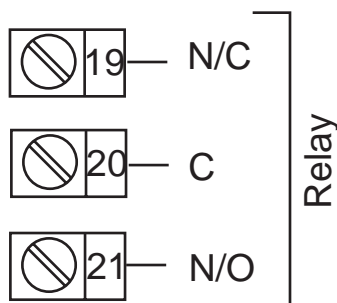

FIGURE 2-13

SSR Driver Output 1

Connections are made to Output 1 SSR Driver as illustrated below. The solid state relay driver is a non-isolated 0-4 VDC nominal signal. Output impedance is 250 ohms.

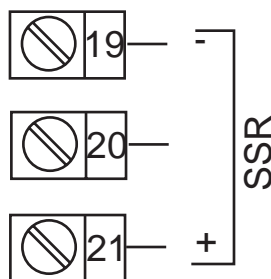

FIGURE 2-14

mADC Output 1

Make connections for DC Output 1 as illustrated below.

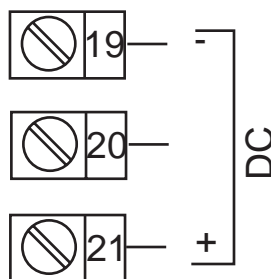

FIGURE 2-15

Relay Output 2

Connections are made to Output 2 relay as illustrated below. The contacts are rated at 2 amp resistive, 120/240 VAC.

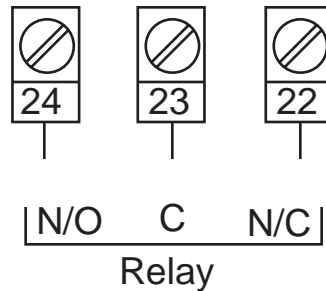

FIGURE 2-16

SSR Driver Output 2

Connections are made to Output 2 SSR Driver as illustrated below. The solid state relay driver is a non-isolated 0-4 VDC nominal signal. Output impedance is 250 ohms.

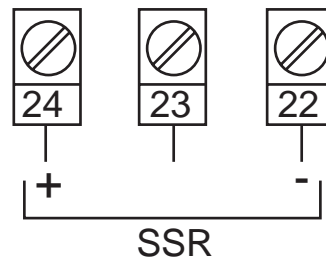

FIGURE 2-17

mADC Output 2

Make connections for DC Output 2 as illustrated below.

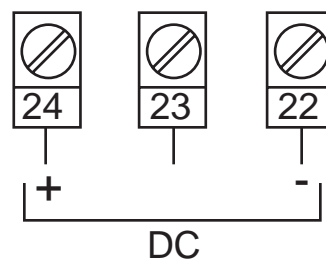

FIGURE 2-18

Relay Output 3

Connections are made to Output 3 relay as illustrated below. The contacts are rated at 2 amp resistive, 120/240 VAC.

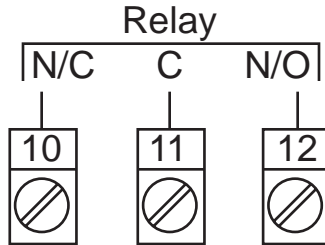

FIGURE 2-19

SSR Driver Output 3

Connections are made to Output 3 SSR Driver as illustrated below. The solid state relay driver is a non-isolated 0-4 VDC nominal signal. Output impedance is 250 ohms.

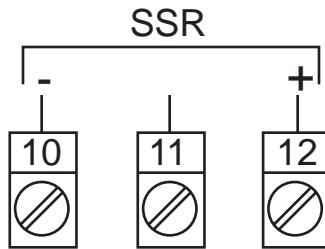
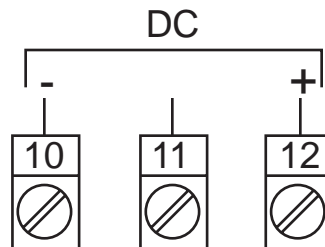

FIGURE 2-20

mADC Output 3 (Recorder Output Only)

Make connections for DC output 3 as illustrated below.



Operation 3.1

3.1.1 POWER UP PROCEDURE

Verify all electrical connections have been properly made before applying power to the instrument.

If the instrument is being powered for the first time, it may be desirable to disconnect the controller output connections. The instrument will be into control following the power up sequence and the output(s) may turn ON. During power up, a self-test procedure is initiated during which all LED segments in the two front panel displays appear and all LED indicators are ON. When the self-test procedure is complete, the instrument reverts to normal operation.

Note: A delay of about 3 seconds, when power is first applied, will be seen before the displays light up.

3.1.2 KEYPAD OPERATION

AUTO/MANUAL KEY

This key is used to:

1. Enter the Auto/Manual mode and vice versa.
2. Used to activate the Auto Tune mode.
3. Used to confirm a change in the Program mode.

SCROLL KEY

This key is used to:

1. Select adjustment of the ramping setpoint, if enabled.
2. Select a parameter to be viewed or adjusted.
3. Display enabled modes of operation.
4. Display a mode parameter value.
5. Advance display from a parameter value to the next parameter code.
6. Activate the Pre-tune mode.
7. With the DOWN key to view the current Hardware Definition Code setting.

UP KEY

This key is used to:

1. Increase the displayed parameter value.
2. Increase setpoint.
3. With the DOWN key to enter Pre and Auto Tune mode.

DOWN KEY

This key is used to:

1. Decrease the displayed parameter value.
2. Decrease setpoint.
3. With the UP key to enter the Pre and Auto Tune mode.
4. With the SCROLL key to view the current Hardware Definition Code setting.

3.1.3 DISPLAYS

During configuration the upper display shows the parameter setting. The lower display shows the parameter code for the currently selected parameter. During operation, the upper display shows the value of the process variable. The lower display shows the setpoint value.

3.1.3.1 ALARM STATUS DISPLAY*

The user may view the status of the instrument's alarm(s) by depressing the SCROLL key until the lower display shows the legend "ALSt" and the upper display shows the alarm status in the following format:

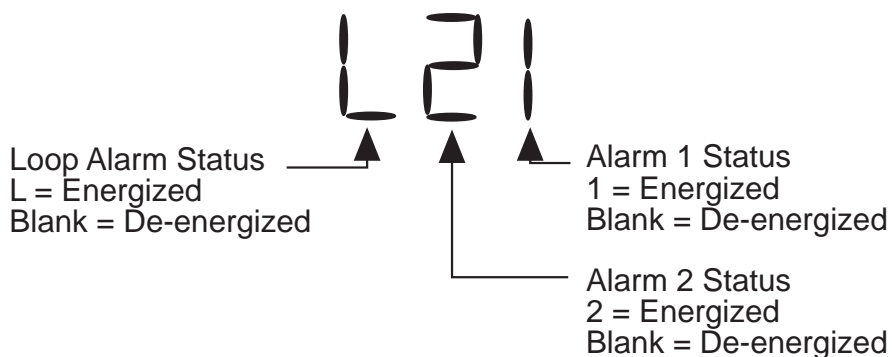

*This display is available only if one or more of the alarms is/are energized.

When "ALSt" is seen in the lower display, to enter the Program or Tune modes, press the UP key with "ALSt" displayed, then the SCROLL key to Program or Tune.

3.1.3.2 OVER-RANGE/UNDER-RANGE DISPLAY

If the process variable attains a value higher than the input scale maximum limit, the upper display will show:

A seven-segment display showing the characters 'HHH'. The first digit is 'H', the second is 'H', and the third is 'H'. Each digit is formed by the top, top-left, top-right, and bottom segments.

If the process variable attains a value lower than the input scale minimum, the upper display will show:

A seven-segment display showing the characters 'LLL'. The first digit is 'L', the second is 'L', and the third is 'L'. Each digit is formed by the top, top-left, bottom-left, and bottom segments.

If a break is detected in the sensor circuit, the upper display will show:

A seven-segment display showing the characters 'SnSr'. The first digit is 'S', the second is 'n', the third is 'S', and the fourth is 'r'. Each digit is formed by the top, top-left, top-right, and bottom segments.

3.1.4 FRONT PANEL INDICATORS

- 1** Indicates the state of the Output 1 relay or SSR driver. When the indicator is ON the relay is energized or the SSR driver is ON.
- 2** Indicates the state of the Output 2 relay or SSR driver. When the indicator is ON the relay is energized or the SSR driver is ON.

ALM When flashing, indicates an Alarm condition.

MAN Flashes when the Manual mode has been entered

AT Indicates when the Pre-Tune mode or Auto-Tune mode has been selected; flashing for Pre-Tune and continuously ON for Auto-Tune.

3.1.5 SETPOINT ADJUSTMENT

3.1.5.1 LOCAL SETPOINT

To adjust the instrument setpoint, proceed as follows:

To adjust the Setpoint, press the UP or DOWN key as applicable. Momentary depression will increment or decrement (as appropriate) the setpoint by one unit in the least significant digit. If the key is held for longer than 1 second, the least significant digit will change at the rate of 25 units per second. If the key is held for longer than 10 seconds, the second least significant digit will change at the rate of 25 units per second. If the key is held for more than 10 seconds, the third least significant digit will change at the rate of 25 units per second.

3.1.5.2 RAMPING SETPOINT

A selectable Ramp Rate function in the range of 1 to 9999 units per hour can be used to limit the rate at which the setpoint used by the control algorithm will change. This feature will also establish a soft start up. Upon power up, the instrument will take the initial process value as the setpoint. A setpoint ramp rate will be calculated to increase the setpoint from the initial process value to the setpoint selected. The setpoint ramp feature disables the Pre-Tune facility. The Auto-Tune facility, if selected, will commence only after the setpoint has completed the ramp.

Sudden changes in the setpoint value entered via the keypad can be inhibited from effecting the control outputs by use of this feature. The internal setpoint used to control the process will ramp to the setpoint value entered at the rate of change selected.

To view the Ramping Setpoint value while in the Control mode and "ESPr" in the Tune mode is disabled, press the SCROLL key until "SPrP" is displayed in the lower display. This is the code for the ramping setpoint value. Press the SCROLL key one more time and the lower display shows "SPrP" and the upper display will show the current ramping setpoint.

SPRr not OFF and ESPr equal to 0



If ESPr is enabled, the display sequence changes to:



*Adjustable

To enter the Program or Tune mode when setpoint ramping is selected, press the SCROLL key until the lower display shows "SPrP" or "SPrr" and the upper display is blank. With "SPrP" or "SPrr" display in the lower display, press the UP key once and "Ctrl" should be displayed in the lower display. With "Ctrl" displayed, press the SCROLL key until "Prog" or "tunE" is displayed in the lower display.

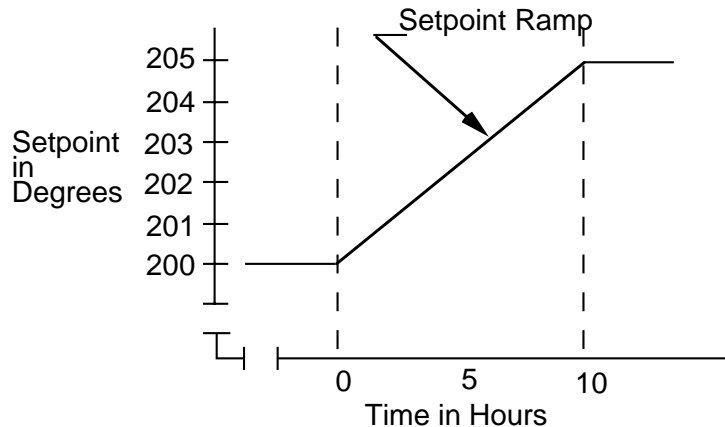

3.1.6 MANUAL CONTROL

Manual Control is not applicable if the Auto/Manual selection in Tune mode is disabled.

To enter the Manual mode, press the AUTO/MANUAL key. The Manual mode status LED will begin to flash indicating that the Manual mode is in use. Shifting from the Control to the Manual mode is bumpless. The proportional output(s) will stay at the last value(s) calculated by the control algorithm. The upper display will show the current process value. The lower display will show the current value output power in the form PXXX where X is equal to the percentage of output power. The value of output power may be adjusted using the UP and DOWN keys, as required.

The output power value can be varied in the range 0% to 100% for instruments using Output 1 only, and -100% to +100% for instruments with both Output 1 and Output 2.

To exit from the Manual mode, press the Auto/Manual key. Shifting to the Control mode is bumpless.

Configuration 3.2

All configurable parameters are provided in Tables 3-1 through 3-3 on the following pages. These tables illustrate the display sequence, parameter adjustment and factory setting for each step.

Depression of the SCROLL key will cycle the display if Setpoint Ramp Rate is not enabled (top display is blank, lower display shows the parameter code) through all enabled modes as follows:

CONTROL ----	PROGRAM ----	TUNE
(Ctrl)	(Prog)	(tunE)

If a mode is not enabled it will be skipped over by the routine.

3.2.1 ENABLE MODE

The Enable mode provides a means of enabling or disabling access to the Program and Tune modes. If a mode has been disabled, then that mode will not be displayed or available to the user in the Control mode. See Table 3-1 (page 27) for the Enable Mode procedure.

3.2.2 PROGRAM MODE

The Program mode is used to configure or re-configure the instrument. The input and output selections are made in the Program mode. All possible parameters are illustrated in Table 3-2 (page 27). Only those parameters that are applicable to the hardware options chosen will be displayed.

3.2.3 TUNE MODE

The Tune mode is used to adjust the tuning parameters, alarm settings, setpoint limits, and retransmit scaling needed for proper operation of the instrument. See Table 3-3 (page 29) for Tune mode. Only those parameters that are applicable will be displayed.

TABLE 3-1 ENABLE MODE

To enter the Enable mode, press and hold the UP and DOWN keys. After 5 seconds (the AT LED should have flashed once), the display returns to normal. After 5 more seconds, "EnAb" will be displayed. Release the keys, the display should show "EPro". Pressing the DOWN key will display the Enable mode codes in the following sequence:

EPro - - Etun - - ESPC

Pressing the SCROLL key will display the Enable mode codes with the upper display blank. The next depression of the SCROLL key will add the Enable code status (ON or OFF) to the upper display. With the Enable code status displayed, use the UP key to change the status to ON and the DOWN key to change the status to OFF.

To exit the Enable mode, press the UP key with the Enable code displayed in the lower display and the upper display blank.

STEP	DESCRIPTION	DISPLAY CODE	AVAILABLE SETTINGS	FACTORY SETTING
1	Program Mode	EPro	ON/OFF	ON
2	Tune Mode	Etun	ON/OFF	ON
3	Setpoint Changes	ESPC	ON/OFF	ON

TABLE 3-2 PROGRAM MODE

To enter the Program mode, press and release the SCROLL key until "Prog" is displayed. Use the DOWN key to enter the Program mode. Depress and release the SCROLL key to sequence through the parameters and their values, alternately showing the parameter code in the lower display with the upper display blank, then the parameter code with the parameter value displayed. Use the UP and DOWN keys to adjust the parameter values. After adjusting a parameter, the upper display will flash, indicating that the new setting has yet to be confirmed. When the setting is as required, it may be confirmed by pressing the AUTO/MANUAL key and the upper display stops flashing. After confirming a change, press the SCROLL key to proceed to the next parameter. Use the DOWN key to advance to the next parameter when a parameter code is showing in the lower display and the upper display is blank.

To exit the Program mode, press the UP key whenever a parameter code is displayed in the lower display and the upper display is blank.

DEFAULT PARAMETER INDICATION

If a parameter value, such as Input Select, was changed while in the Program mode, when returning to the Control mode, a decimal point after each digit will be lit. This display indicates all Tune mode parameters have been set to their default condition. To clear this condition, enter the Tune mode and make a parameter value change and review each parameter for its proper setting.

STEP	DESCRIPTION	DISPLAY CODE	AVAILABLE SETTINGS	FACTORY SETTING
1	Input Select	inPS	See App. D*	1420
2	Output 1 Action	Out1	Reverse Direct	REV
3	Alarm 1 Type	ALA1	P_hi =Proc High nonE=No Alarm bAnd=Band dE =Deviation P_Lo=Proc Low	P_hi
4	Alarm 2 Type	ALA2	Same selection as ALA1	nonE
5	Output 2 Usage	USE2	Out2 =Control (opposite of Out1 action) LP_r =Loop Reverse LP_d=Loop Direct Ad_r =Rev Logic AND Ad_d=Dir Logic AND Or_r =Rev Logic OR Or_d =Dir Logic OR A2_r =Alm Rev A2_d=Alm Dir	Out2
6	Output 3 Usage	USE3	Al_d =Alm Dir rEcP =Rcdr Out P.V. rEcS =Rcdr Out S.P. LP_r =Loop Reverse LP_d=Loop Direct Ad_r =Rev Logic AND Ad_d=Dir Logic AND Or_r =Rev Logic OR Or_d=Dir Logic OR Al_r =Alm Rev	Al_d
7	Com Bit Rate	CbS	1200, 2400, 4800, 9600	4800

STEP	DESCRIPTION	DISPLAY CODE	AVAILABLE SETTINGS	FACTORY SETTING
8	Com Address	CAd	1 - 32	1
9	CJC Enable	CJC	EnAb diSA	EnAb

* The Hardware Definition Code and input jumper configuration may need to be changed. See Appendix B and C.

TABLE 3-3 TUNE MODE

To enter the Tune mode, press and release the SCROLL key until tunE is displayed. Use the DOWN key to enter the Tune mode. Depress and release the SCROLL key to sequence through the parameters and their values, alternately showing the parameter code in the lower display with the upper display blank, then the parameter code with the parameter value displayed. Use the UP and DOWN keys to adjust the parameter values. After adjusting a parameter, depress the SCROLL key to proceed to the next parameter. Use the DOWN key to advance to the next parameter when a parameter code is showing in the lower display and the upper display is blank.

To exit the Tune mode, press the UP key whenever a parameter code is displayed in the lower display and the upper display is blank.

1	Ramping Setpoint Value	SPrP	± Setpoint Limits	Read Only
2	Setpoint Ramp Rate	SPrr	1 to 9999 units/hour and OFF	OFF
3	Input Filter	Filt	0.0 to 100.0 seconds in .5 sec. increments	2.0
4	Input Correct	iCor	± Span	0
5	Output 1%	Po1	0 to 100%	Read Only

(Continued on next page)

STEP	DESCRIPTION	DISPLAY CODE	AVAILABLE SETTINGS	FACTORY SETTING
6	Output 2%	Po2	0 to 100%	Read Only
7	1st Output Prop. Band	Pb1	0 to 999.9% of Input Span 0%=On/OFF	5.0
8	2nd Output Prop. Band	Pb2	0 to 999.9% of Input Span 0%=ON/OFF	5.0
9	Automatic Reset	ArSt	OFF to 99 mins. 59 secs	OFF
10	Rate	rAtE	0 sec to 99 mins. 59 secs.	0 secs.
11	Overlap/ Deadband	SPrd	-20 to 20% of Pb1 and Pb2	0%
12	Manual Reset	rSEt	0 to 100% Output 1 -100 to 100% Out 2	25%
13	Hysteresis Output 1 Output 2 Out 1 & Out 2	HyS1 HyS2 HySt	0.1 to 10.0% of span 0.1 to 10.0% of span 0.1 to 10.0% of span	0.5 0.5 0.5
14	Setpoint Upper Limit	SPuL	Span Max.	Span Max.
15	Setpoint Lower Limit	SPLL	Span Min.	Span Min.
16	Process Output Upper	Pou	-1999 to 9999	Span Max.

STEP	DESCRIPTION	DISPLAY CODE	AVAILABLE SETTINGS	FACTORY SETTING
17	Process Output Lower	PoL	-1999 to 9999	Span. Min.
18	Output 1 % Limit	o1PL	0 to 100%	100
19	Output 1 Cycle Time	Ct1	.5, 1, 2, 4, 8, 16, 32, 64, 128, 256, 512 secs	32
20	Output 2 Cycle Time	Ct2	.5, 1, 2, 4, 8, 16, 32, 64, 128, 256, 512 secs	32
21	Process High Alarm 1	PHA1	± Span	Span Max.
22	Process Low Alarm 1	PLA1	± Span	Span Min.
23	Band Alarm 1	bAL1	0 to Span	5
24	Deviation Alarm 1	dAL1	± Span	5
25	Process High Alarm 2	PHA2	± Span	Span Max.
26	Process Low Alarm 2	PLA2	± Span	Span Min.
27	Band Alarm 2	bAL2	0 to Span	5
28	Deviation Alarm 2	dAL2	± Span	5

STEP	DESCRIPTION	DISPLAY CODE	AVAILABLE SETTINGS	FACTORY SETTING
29	Loop Alarm Enable	LAEn	0=Disable 1=Enable	0
30	Loop Alarm Time	LAti	1 sec to 99 mins. 59 secs.	99 mins. 59 secs.
31	Decimal Position	dPoS	0, 1, 2, 3 (Linear Input Only)	1
32	Engineering Units Upper	Euu	-1999 to 9999	1000
33	Engineering Units Lower	EuL	-1999 to 9999	0
34	*Enable Pre Tune	EPtn	0=Disable 1=Enable	0
35	Enable Manual Control	ESby	0=Disable 1=Enable	0
36	**Setpoint Ramp Rate Enable	ESPr	0=Disable 1=Enable	0
37	Comm. Enable	CCon	0=Disable 1=Enable	1

* Activates Pre-Tune on power-up when enabled.

** When enabled, allows user to change ramp rate without having to enter Tune mode.

Pre-Tune Mode 3.3

The Pre-Tune mode may be used to set the instrument's PID parameters to values which are approximately correct, in order to provide a base from which the Auto Tune mode may optimize tuning.

To engage the Pre-Tune mode, with the instrument in Control mode, press and hold the UP and DOWN keys for approximately 5 seconds (the display will flash during this period) until the AT LED flashes once. Release the UP and DOWN keys. Press and hold the SCROLL key for approximately 3 seconds until the AT LED flashes.

To disengage the Pre-Tune mode, press and hold the UP and DOWN keys until the AT LED flashes once. Release the UP and DOWN keys. Press and hold the SCROLL key for approximately 3 seconds until the AT LED is continuously OFF.

Note: Since the Pre-Tune mode is a single-shot operation, it will automatically disengage itself once the operation is complete. If the Enable Pre-Tune parameter in the Tune mode is enabled, then a power interruption, the unit will first engage the Pre-Tune mode prior to engaging the Auto-Tune mode when power is restored.

Also note: The Pre-Tune mode will not engage during setpoint ramping. Additionally, if the process variable is within 5% of input span from the setpoint, or if an incorrect key sequence is used, the Pre-Tune mode will not be engaged.

Auto-Tune Mode 3.4

The Auto-Tune mode is used to optimize tuning while the instrument is operating.

To engage the Auto-Tune mode, with the instrument in Control mode, press and hold the UP and DOWN keys for approximately 5 seconds (the display will flash during this period) until the AT LED flashes once. Release the UP and DOWN keys. Press and hold the AUTO/MAN key for approximately 3 seconds until the AT LED lights continuously.

Note: If the Enable Pre-Tune parameter in the Tune mode is enabled, then on power-up, the unit will automatically engage the Pre-Tune mode prior to engaging the Auto-Tune mode when power is restored.

To disengage the Auto-Tune mode, press and hold the UP and DOWN keys until the AT LED flashes once. Release the UP and DOWN keys. Press and hold the AUTO/MAN key for approximately 3 seconds until the AT LED is continuously OFF.

Manual Tuning Method 3.5

1. Cycle Time - Time Proportioning Outputs
 - A. Adjusting the cycle time affects instrument operation
 1. Shorter Cycle Time
 - a. More accurate control
 - b. Shorter life span of electromechanical components
2. Proportional Bandwidth
 - A. Proportional Bandwidth is the inverse of gain.
Increased Bandwidth = Decreased Gain
 - B. Increase the Proportional Bandwidth if:
 1. The process overshoots excessively
 2. The process oscillates excessively
 - C. Decrease the Proportional Bandwidth if:
 1. The process responds slowly
 2. The process fails to reach setpoint
3. Add Automatic Reset
 - A. Increase the Automatic Reset until the process becomes unstable, then decrease until stability is restored.
 - B. Be sure to allow sufficient time for the process and the instrument to react.
4. Rate Adjustment
 - A. Rate can cause process instability. Typically add Rate as 1/10 th of the automatic reset value.
 - B. Decrease Rate if:
 1. The process overshoots/undershoots
 2. If the process oscillates excessively

5. Manual Reset

- A. After making all other adjustments, use if an offset exists between the setpoint and the process variable.
- B. If the process is:
 - 1. Below setpoint use a positive Manual Reset value
 - 2. Above the setpoint use a negative Manual Reset value

Control Capability 4.1

A variety of user programmable control features and capabilities are available including:

- Auto Tune
- Time Proportioning Control
- Alarm Functions
- Auto/Manual Switching
- Process Retransmission
- Setpoint Retransmission
- On-Off Control
- Current Proportioning
- Dual Output Control
- Setpoint Adjustment
- Setpoint Ramp Rate

The capabilities available in a specific unit are dependent upon the hardware options specified when the instrument is ordered. Refer to Appendix F for the decoding of the instrument model number. Current proportioning control cannot be implemented if a current output was not ordered. The available output types and quantity of each are as follows:

<u>Type of Output</u>	<u>Quantity Available</u>
• SPDT mechanical relay output	Up to three
• SSR Driver	Up to three
• mADC current output	Up to two

Control Responses 4.2

Each instrument may be configured to provide 3 mode proportional control. Proportional control is provided with Proportional Band, Integration, and Derivative responses. The PID parameters are defined as follows:

		<u>Out 1</u>	<u>Out2</u>
P (Proportional)	Proportional Band	Pb1	Pb2
I (Integration)	Automatic Reset	ArSt	ArSt
D (Derivative)	Rate	rAtE	rAtE

Manual Reset is provided for use in lieu of, or in conjunction with automatic reset. A cycle time adjustment parameter is provided for use with each time proportioning control output.

Direct/Reverse Operation of Outputs 4.3

Direct operation is typically used with cooling applications. On-Off direct output(s) will turn on when the process variable exceeds setpoint. Proportional direct output(s) will increase the percentage of output as the process value increases within the proportional band.

Reverse operation is typically used with heating applications. On-Off reverse output(s) will turn off when the process variable exceeds setpoint. Proportional reverse output(s) will decrease the percentage of output as the process value increases within the proportional band.

On-Off Control 4.4

On-Off control can be implemented with SPDT relay or SSR driver output(s). On-Off operation can be assigned to Output 1 only OR Output 1 AND Output 2, but not Output 2 only.. A hysteresis adjustment is provided for On-Off outputs. This adjustment is in % of input span and defines the bandwidth of the hysteresis. Relay chatter can be eliminated by proper adjustment of this parameter. When operating in On-Off control, the output(s) will turn on or off depending upon the setpoint, the process value, and the hysteresis adjustment.

Time Proportioning Control 4.5

Time Proportioning control can be implemented with a SPDT relay or SSR driver. Time proportioning control can be selected for either Output 1 or Output 1 and Output 2, depending on hardware configuration. Time proportioning control is accomplished by cycling the output on and off during a prescribed period of time when the process variable is within the proportional band.

Ex: Calculated output % = 40%; Cycle time adjustment = 32 seconds
Output on time = $.4 \times 32 = 12.8$ seconds
Output off time = $.6 \times 32 = 19.2$ seconds

When the unit is operating in the Control mode, the control algorithm determines the output % required to correct for any difference between the process value and the setpoint. The output calculation is affected by Tune mode parameter adjustments. See Figure 4-1 (page 38) for proportional bandwidth effect on the output.

Current Proportioning Control 4.6

Current Proportioning control can be implemented on units provided with mADC current output(s). Current Proportioning control provides a 4 to 20mADC or 0-20mADC output in response to process value and setpoint. As with Time proportioning, the calculated output % for Current proportioning is affected by the Tune mode parameter adjustments.

See Figure 4-1 (below) for proportional bandwidth effect on the output.

FIGURE 4-1

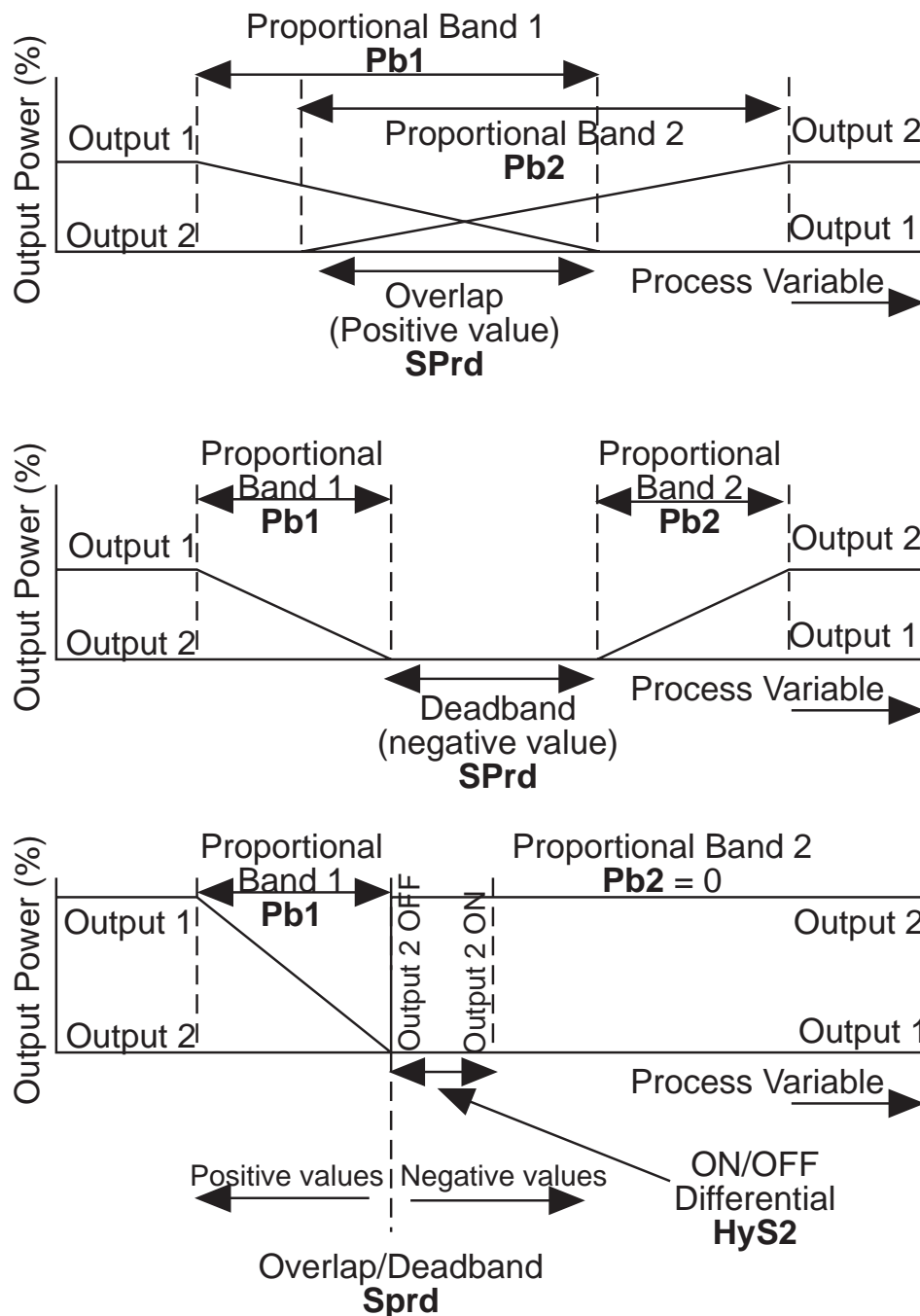

Setpoint Adjustment 4.7

To adjust the setpoint with the instrument in the Control mode, press the UP key to raise the setpoint and the DOWN key to lower the setpoint.

Depressing the SCROLL key, if setpoint ramping is enabled and if ramp rate is not OFF will change the displays to:

Upper Display = Ramping Setpoint Value (Read Only)

Lower Display = SPrP

Appendix A

Glossary of Terms

Input Filter Time Constant

This parameter is used to filter out any extraneous impulses on the process variable. This filtered PV is used for all PV-dependent functions (control, alarm, etc). The time constant is adjustable from 0.0 seconds (off) to 100.0 seconds, in 0.5 second increments. Default value is 2.0 seconds. Display code is FiLt.

Input Correction

This parameter is used to modify the actual process variable and is adjustable in the range \pm input span. Default value is 0. Display code is iCor.

Proportional Band 1

This parameter is the portion of the input span over which the Output 1 power level is proportional to the displayed process variable value. It may be adjusted in the range 0.0% (ON/OFF) to 999.9%. Default value is 5.0%. Display code is Pb1. The function is illustrated in Figure A-1, page 50.

Proportional Band 2

This parameter is the portion of the input span over which the Output 2 power level is proportional to the displayed process variable value. It may be adjusted in the range 0.0% (ON/OFF) to 999.9%. Default value is 5.0%. Display code is Pb2. In Figure A-1 (page 46), Proportional Band 2 is shown (a) with a nonzero value (Case 1 and Case 2) - PID Control, and (b) with a zero value (Case 3) - ON-OFF control.

Automatic Reset (Integral)

This parameter is used to bias the proportional output(s) to compensate for process load variations. It is adjustable in the range 1 second to 99 minutes 59 seconds and OFF (value greater than 99 minutes 59 seconds). This parameter is not available if Pb1 is set to 0. Default value is OFF. Display code is ArSt.

Rate (Derivative)

This parameter is adjustable in the range 00 seconds to 99 minutes 59 seconds and specifies how the control action responds to the rate of change in the process variable. This parameter is not available if Pb1 is set to 0. Default value is 0.0. Display code is rAtE.

Overlap/Deadband

This parameter defines the portion of the proportional band (Pb1 + Pb2) over which both outputs are active (or, in the case of a deadband, neither output is active). It is adjustable in the range -20% to +20% (negative value = deadband). The function is illustrated in Figure A-1, page 50. This parameter is not applicable if Pb1 = 0 or if there is no Output 2. Default value is 0%. Display code is SPrd.

Note: With Output 2 set on ON/OFF (Figure A-1, page 50, Case 3) the Overlap/Deadband parameter has the effect of moving the ON hysteresis band of Output 2 to create an overlap (positive values) or a deadband (negative values). When Overlap/Deadband = 0, the Output 2 OFF edge of the Output 2 ON/OFF hysteresis band coincides with the point at which Output 1 = 0%.

Manual Reset

This parameter is expressed as a percentage of output power and is adjustable in the range 0% to 100% (if only Output 1) or -100% to +100% (if both Output 1 and Output 2). This parameter is not applicable if Pb1 = 0. Default value is 25%. Display code is rSEt.

Hysteresis

This parameter is a switching differential used when one or both outputs have been set to ON/OFF. This parameter is adjustable within the range 0.1% to 10.0% of input span. Default value is 0.5%. Display code is HyS1, HyS2, HySt.

Setpoint Upper Limit

This parameter is the maximum limit for setpoint adjustment. It should be set to a value which prevents the setpoint being given a value which will cause damage to the process. The range of adjustment is to Maximum Input Range. Default value is Range Maximum. Display code is SPuL.

Setpoint Lower Limit

This parameter is the minimum limit for setpoint adjustment. It should be set to a value which prevents the setpoint being given a value which will cause damage to the process. The range of adjustment is to Minimum Input Range. Default value is Range Minimum. Display code is SPLL.

Process Output Upper Value

This parameter defines the value of the retransmitted output (process variable or setpoint, whichever is applicable) at its maximum value; for example, for a 0-5V output, this value corresponds to 5V. It may be adjusted within the range -1999 to 9999. The decimal position is always the same as that for the process variable input. Default value is Input Range Maximum. Display code is Pou.

Note: If this parameter is set to a value less than that for the Process Output Lower Value, the relationship between the process variable/setpoint value and the retransmission output is reversed.

Process Output Lower Value

This parameter defines the value of the retransmitted output (process variable or setpoint, whichever is applicable) at its minimum value; for example, for a 0-5V output, this value corresponds to 0 V. It may be adjusted within the range -1999 to 9999. The decimal position is always the same as that for the process variable input. Default value is Input Range Minimum. Display code is PoL.

Note: If this parameter is set to a value greater than that for the Process Output Upper Value, the relationship between the process variable/setpoint value and the retransmission output is reversed.

Output 1 Percent Limit

This parameter is used to limit the power level of Output 1 and may be used to protect the process being controlled. It may be adjusted between 0 % and 100%. This parameter is not applicable if Pb1 = 0. Display code is o1PL.

Cycle Time

This parameter is used to select the on/off cycle time for time proportioning outputs (Ct1 for Output 1 and Ct2 for Output 2). The permitted range of value is 0.5, 1, 2, 4, 8, 16, 32, 64, 128, 256, or 512 seconds. Default value is 32. Display codes Ct1 & Ct2.

Process High Alarm 1 Value

This parameter, applicable only when Alarm 1 is selected to be a Process High alarm, defines the process variable value at or above which Alarm 1 will be active. Its value may be adjusted between Input Range Maximum and Input Range Minimum. Its default value is Input Range Maximum. Display code is PHA1.

Process Low Alarm 1 Value

This parameter, applicable only when Alarm 1 is selected to be a Process Low alarm, defines the process variable value at or below which Alarm 1 will be active. Its value may be adjusted between Input Range Maximum and Input Range Minimum. Its default value is Input Range Minimum. Display code is PLA1.

Band Alarm 1 Value

This parameter, applicable only if Alarm 1 is selected to be a Band Alarm, defines a band of process variable values, centered on the setpoint value. If the process variable value is outside this band, the alarm will be active. This parameter may be adjusted from 0 to span from the setpoint. The default value is 5. The display code is bAL1.

Deviation Alarm 1 Value

This parameter, applicable only if Alarm 1 is selected to be a Deviation High/Low Alarm, defines a value above (positive value - Deviation High Alarm) or below (negative value - Deviation Low Alarm) the setpoint; if the process variable deviates from the setpoint by a margin greater than that defined by this parameter, Alarm 1 goes active. This parameter may be adjusted in the range \pm span from setpoint. The default value is 5. Display code is dAL1.

Process High Alarm 2 Value

This parameter, applicable only when Alarm 2 is selected to be a Process High Alarm, defines the process variable value at or above which Alarm 2 will be active. Its value may be adjusted between Input Range Maximum and Input Range Minimum. Its default value is Input Range Maximum. Display code is PHA2.

Process Low Alarm 2 Value

This parameter, applicable only when Alarm 2 is selected to be a Process Low Alarm, defines the process variable value at or below which Alarm 2 will be active. Its value may be adjusted between Input Range Maximum and Input Range Minimum. Its default value is Input Range Minimum. Display code is PLA2.

Band Alarm 2 Value

This parameter, applicable only if Alarm 2 is selected to be a Band Alarm, defines a band of process variable values, centered on the setpoint value. If the process variable is outside this band, the alarm will be active. This parameter may be adjusted from 0 to span from the setpoint. The default value is 5. Display code is bAL2.

Deviation Alarm 2 Value

This parameter, applicable only if Alarm 2 is selected to be a Deviation High/Low Alarm, defines a value above (positive value - Deviation High Alarm) or below (negative value - Deviation Low Alarm) the setpoint; if the process variable deviates from the setpoint by a margin greater than that defined by this parameter, Alarm 2 goes active. This parameter may be adjusted in the range \pm span from setpoint. The default value is 5. Display code is dAL2.

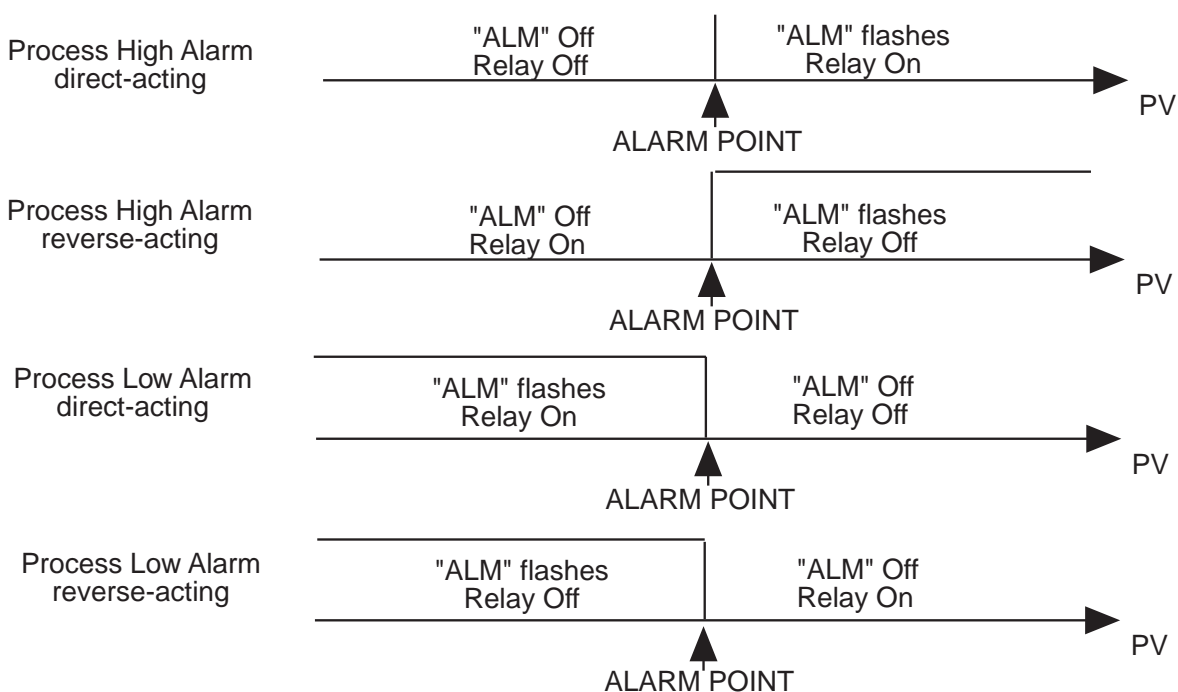

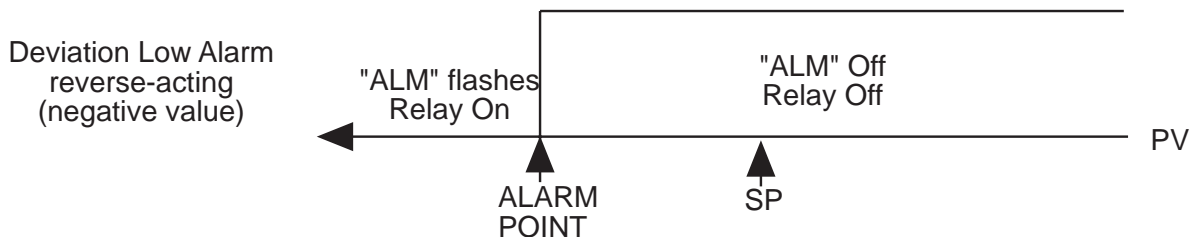
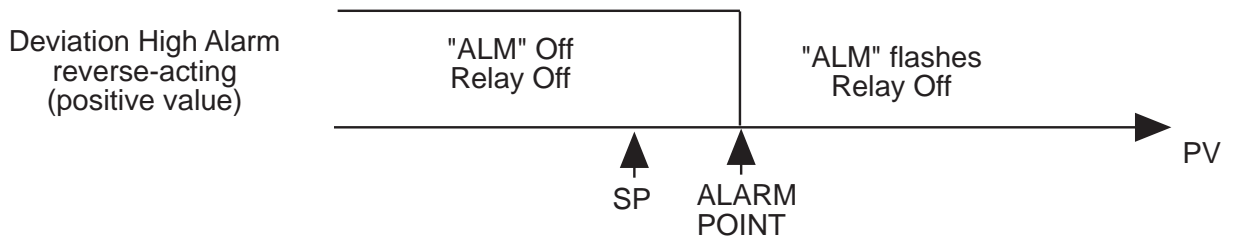
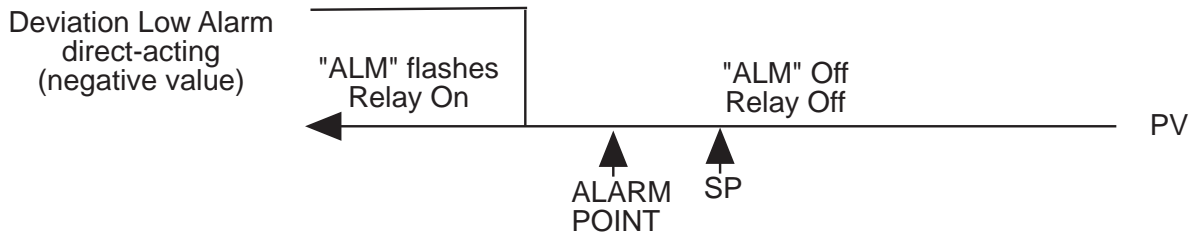
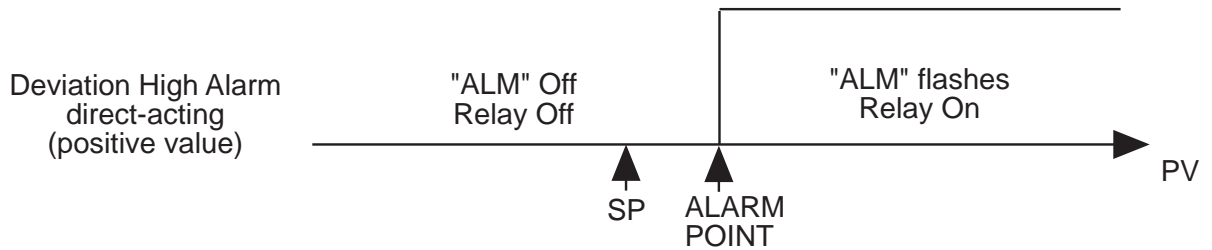
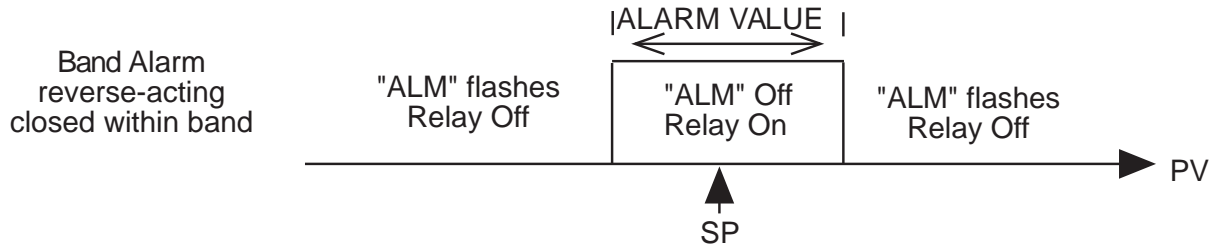
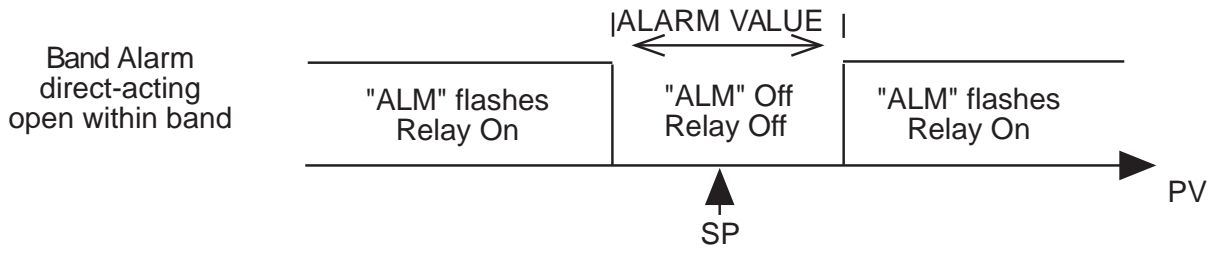

Loop Alarm Enable

This parameter is the means by which the user can enable or disable the Loop Alarm. The Loop Alarm is a special alarm which detects faults in the control feedback loop by continuously monitoring process variable response to the control output(s).

The Loop Alarm, when enabled, repeatedly checks the control output(s) for being at the maximum or minimum limit. If an output is found to be at the limit, the Loop Alarm mode starts a timer; thereafter, if the high output has not caused the process variable to be corrected by a predetermined amount V after a time T has elapsed, the Loop Alarm goes active. Subsequently, the Loop Alarm mode repeatedly checks the process variable and the control output(s). When the process variable starts to change value in the correct sense or when the output comes below the limit, the Loop Alarm is deactivated.

For PID control, the Loop Alarm Time T is always set to twice the value of the Auto Reset parameter. For ON/OFF control, the user defined value of the Loop Alarm Time Set Up parameter is used.

The value of V is dependent upon the input type:

Deg C:	2°C or 2.0°C
Deg F:	3°F or 3.0°F
Linear Range:	10 least significant display units

For single output instruments, the limits are 0% and Out 1 Max %. For dual output instruments, the limits are -100% and Out 1 Max %.

Notes:

1. Correct operation of the Loop Alarm depends upon reasonably accurate PID tuning.
2. The Loop Alarm is automatically disabled during Manual Control mode and during execution of the Pre-Tune mode. Upon exit from Manual mode or after completion of the Pre-Tune routine, the Loop Alarm is automatically re-enabled.

Loop Alarm Time

When full ON/OFF control is selected and Loop Alarm is enabled, this parameter determines the duration of the limit condition after which the Loop Alarm will be activated. It may be adjusted within the range of 1 second to 99 minutes 59 seconds. This parameter is omitted from the Tune mode display sequence if ON/OFF control is not selected or Loop Alarm is disabled. The default setting 99:59. Display code is LAti.

Logical Combination of Alarms

Two alarms may be combined logically to create an AND/OR situation. They may be configured for Reverse-acting or Direct-acting. Either Output 2 or Output 3 may be assigned as Logical Outputs.

Example:

Logical OR of Alarm 1 with Alarm 2

Direct-Acting

AL1 OFF, AI2 OFF: Relay OFF

AL1 ON, AI2 OFF: Relay ON

AL1 OFF, AI2 ON: Relay ON

AL1 ON, AI2 ON: Relay ON

Reverse-Acting

AL1 OFF, AI2 OFF: Relay ON

AL1 ON, AI2 OFF: Relay OFF

AL1 OFF, AI2 ON: Relay OFF

AL1 ON, AI2 ON: Relay OFF

Logical AND of Alarm 1 with Alarm 2

Direct-Acting

AL1 OFF, AI2 OFF: Relay OFF

AL1 ON, AI2 OFF: Relay OFF

AL1 OFF, AI2 ON: Relay OFF

AL1 ON, AI2 ON: Relay ON

Reverse-Acting

AL1 OFF, AI2 OFF: Relay ON

AL1 ON, AI2 OFF: Relay ON

AL1 OFF, AI2 ON: Relay ON

AL1 ON, AI2 ON: Relay OFF

ASYMMETRICAL BAND ALARM

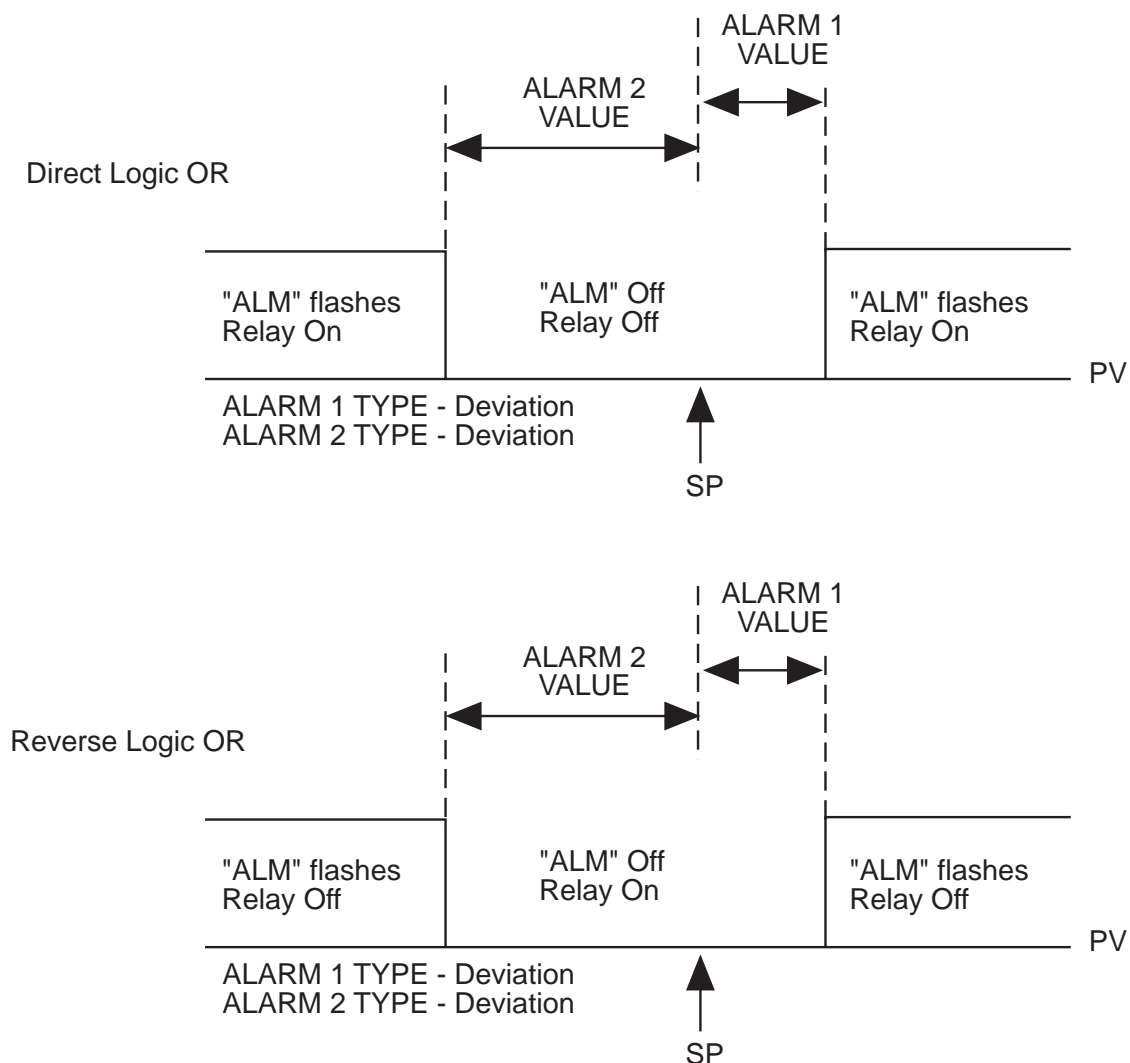

Decimal Point

This parameter, applicable only if a linear input is specified, defines the position of the decimal point in values for the process variable, setpoint, alarm levels and retransmission outputs as follows:

Value	Decimal Point Position
0	XXXX
1	XXX.X
2	XX.XX
3	X.XXX

The default value is 0. Display code is dPoS.

Engineering Units Upper

This parameter, applicable only if a linear input is specified, defines the scaled input value when the process variable input is at its maximum value. It is adjustable between -1999 to 9999. The default value is 1000. This parameter can be set to a value less than (but not equal to) Engineering Units Lower, in which case the sense of the input is reversed. Display code is Euu.

Engineering Units Lower

This parameter, applicable only if a linear input is specified, defines the scaled input value when the process variable input is at its minimum value. It is adjustable between -1999 and 9999. The default value is 0. This parameter can be set to a value greater than (but not equal to) Engineering Units Upper, in which case the sense of the input is reversed. Display code is EuL.

Pre-Tune Enable/Disable

This parameter determines whether or not the instrument Pre-Tune mode is activated on power up or not (0=disabled, 1=enabled). Default is 0. Display code is EPtn.

Manual Mode Enable/Disable

This parameter determines whether operator selection of manual control is enabled or disabled (0=disabled, 1=enabled). The default setting is 0. Display code is ESby.

Setpoint Ramp Enable/Disable

This parameter enables/disables use of the Setpoint Ramp feature (0=disabled, 1=enabled). The default setting is 0. Display code is ESPr.

Communications Enable

This parameter enables/disables the changing of parameter values via the RS485 communications link, if the Communications option is specified. Settings are 0=disabled and 1=enabled. Default setting is 0. Display code is CCon.

FIGURE A-1
Proportional Band & Deadband/Overlap

Case 1

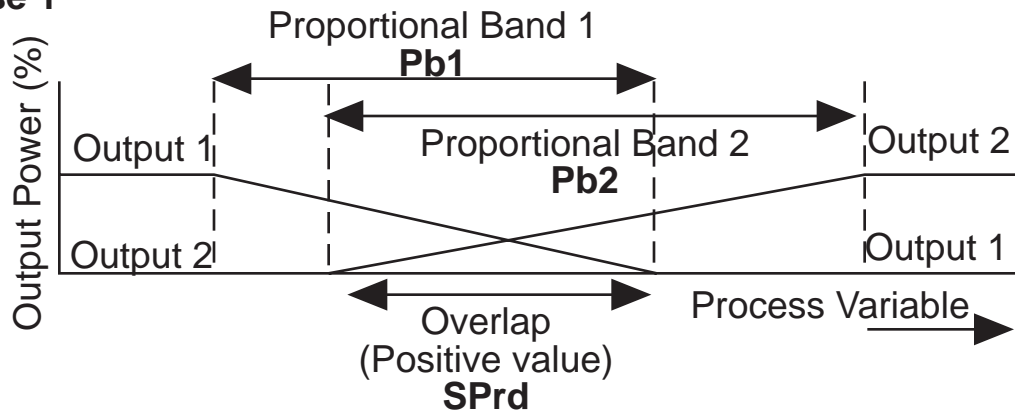

Case 2

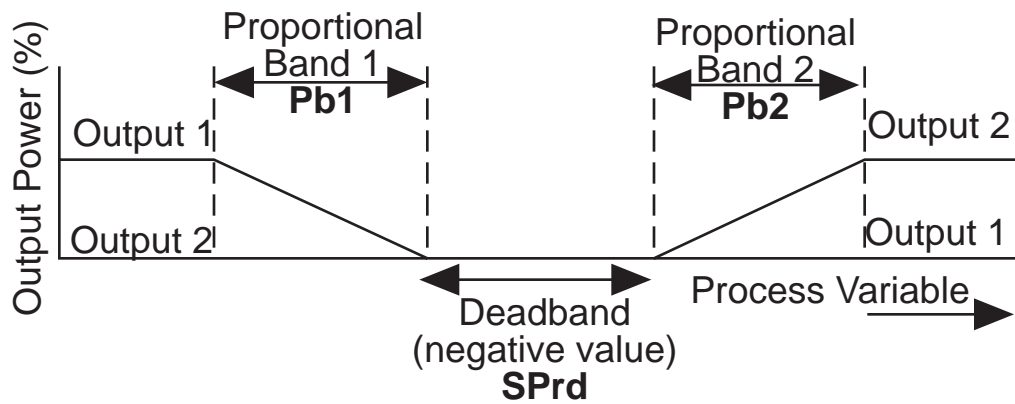

Case 3

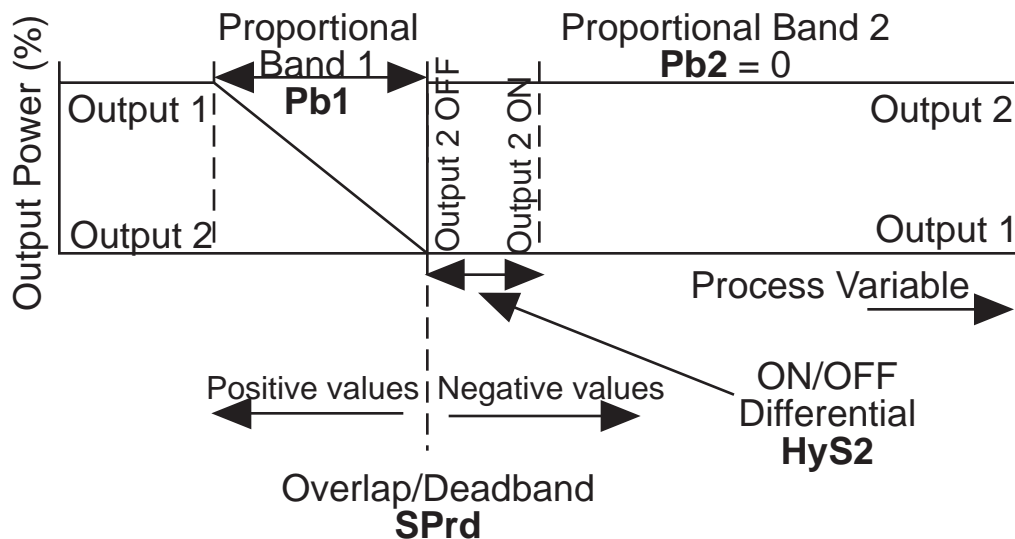

Appendix B

Board Layout - Jumper Positioning

FIGURE B-1 PCB POSITIONS

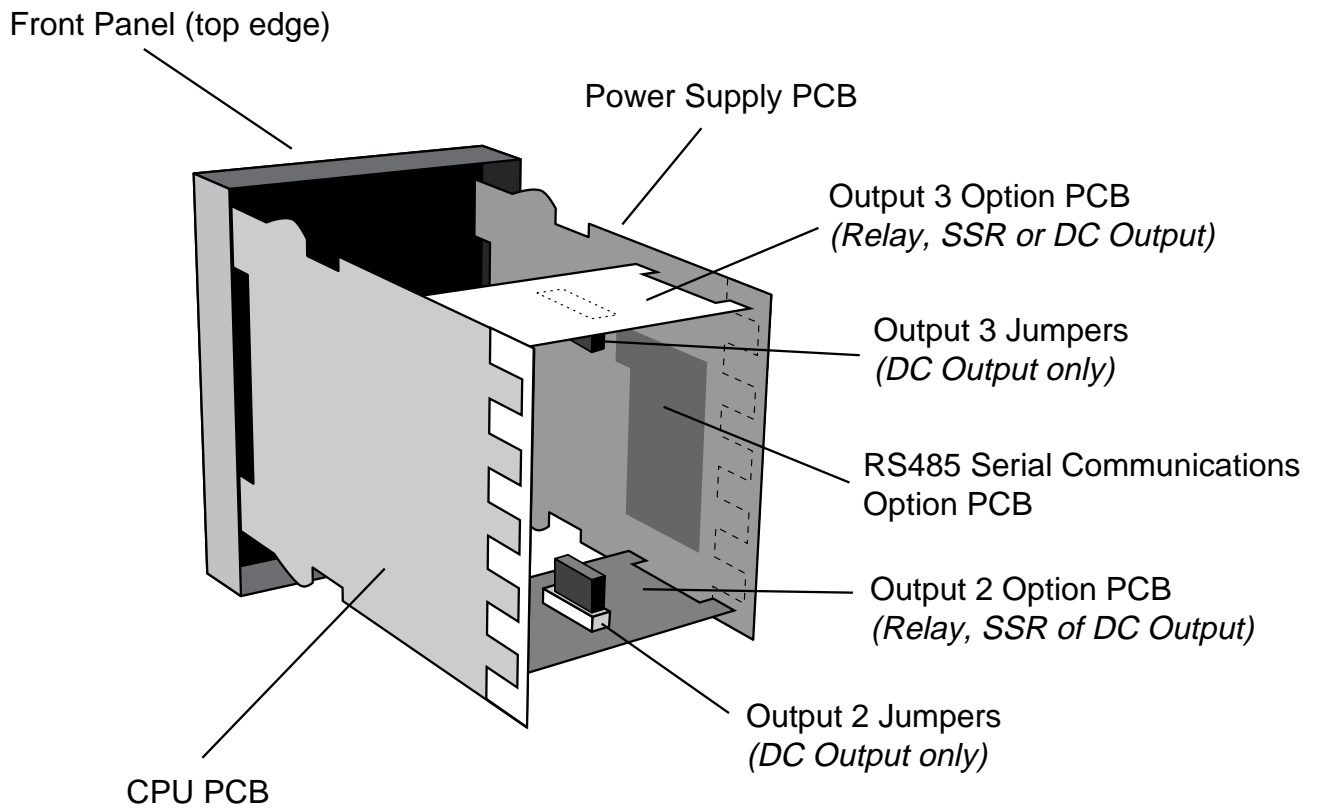
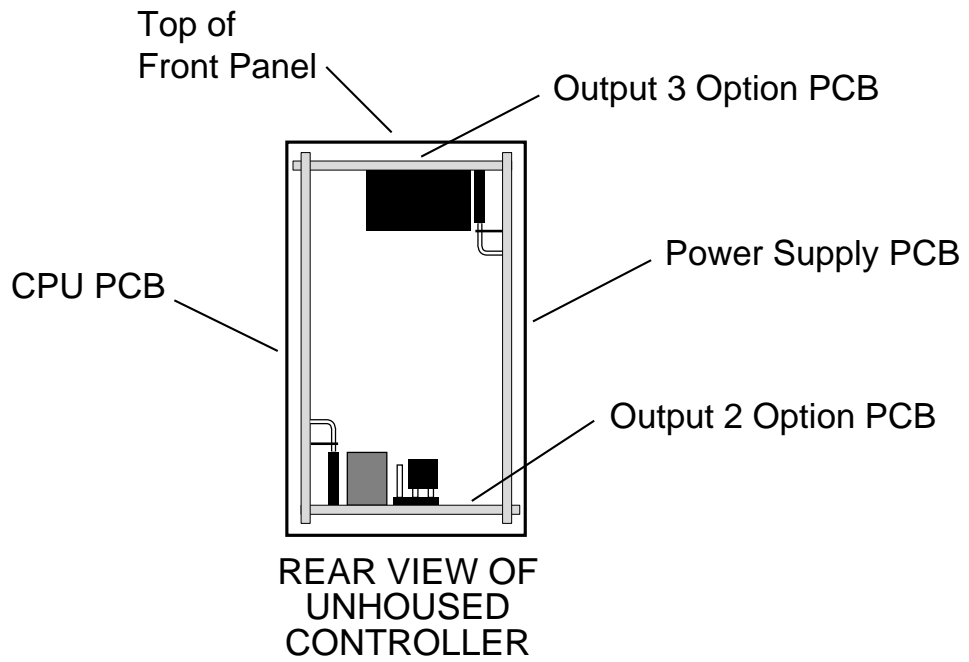
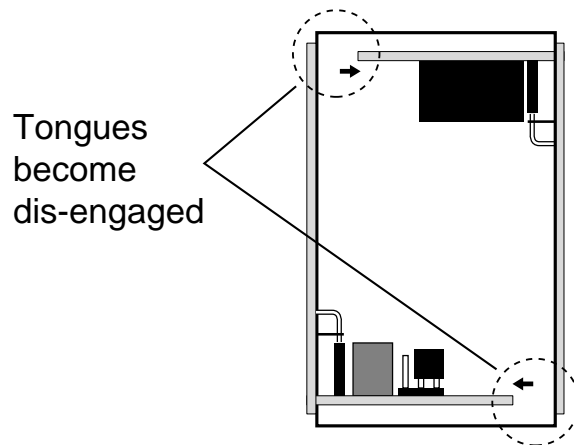

FIGURE B-2 OUTPUT 2, OUTPUT 3 REMOVAL

A



B



C

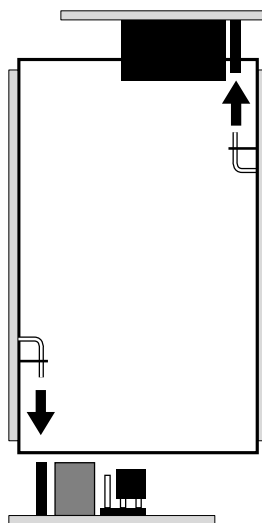
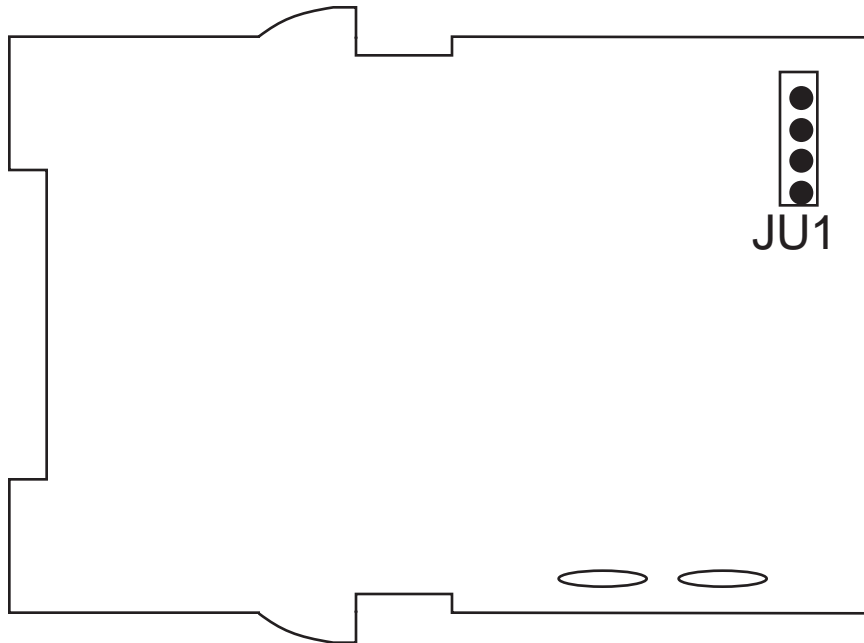

FIGURE B-3 CPU PWA



Input Conditioning Jumper

JU1

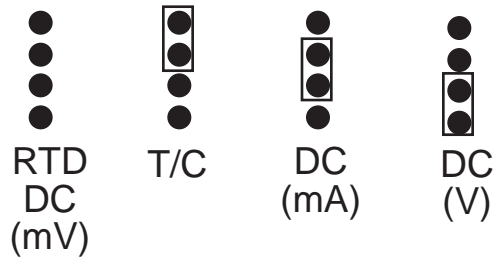

FIGURE B-4 PSU PWA WITH RELAY OR SSR OUTPUT 1

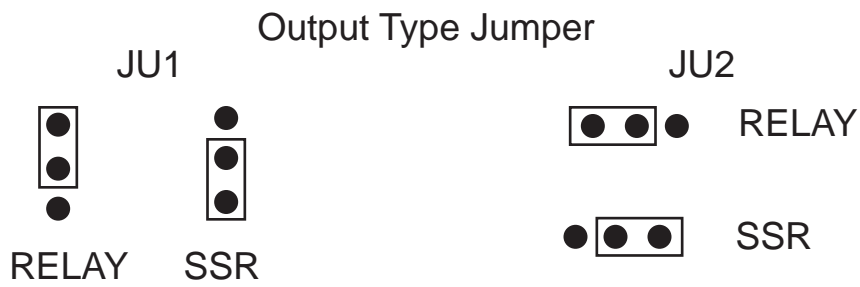
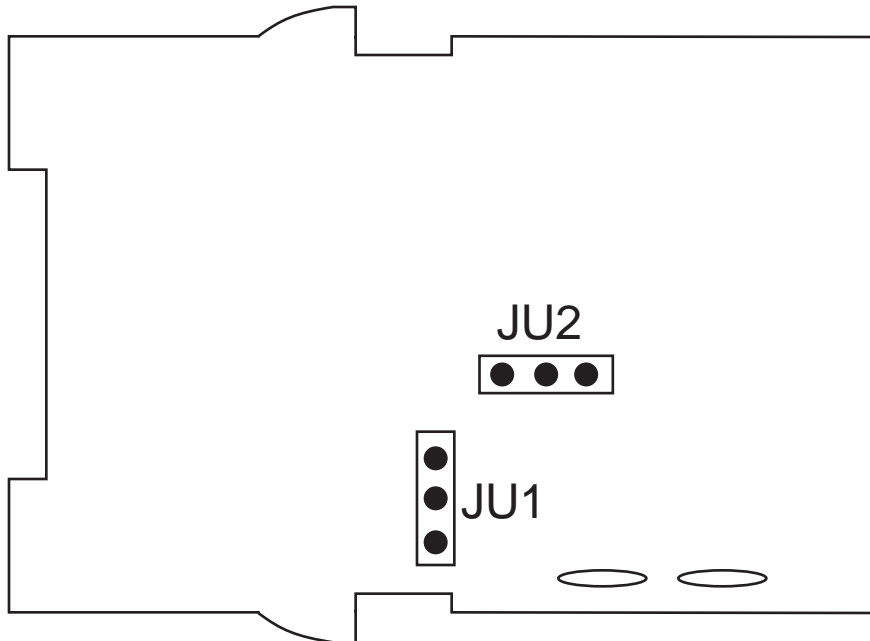
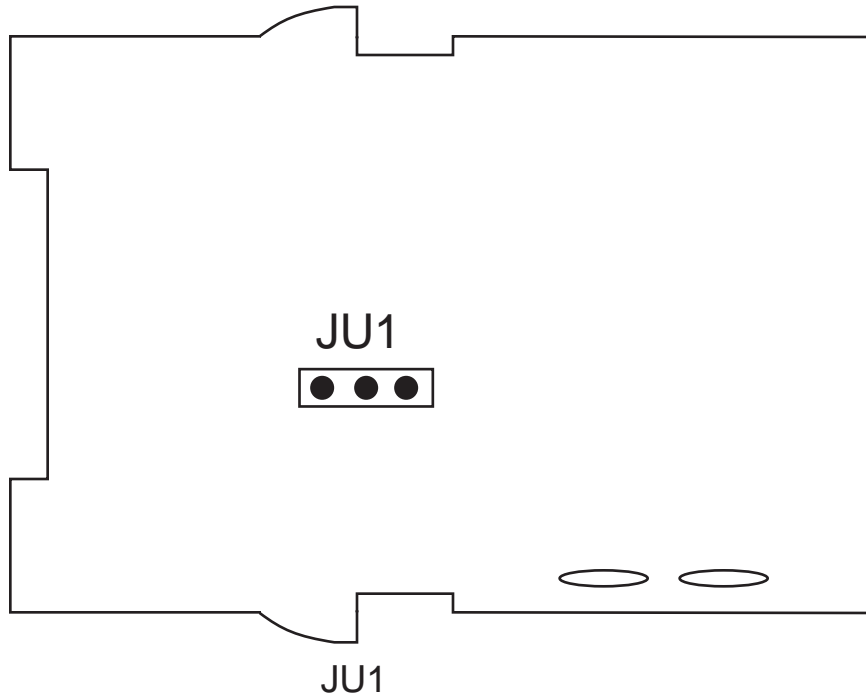





FIGURE B-5 PSU PWA WITH DC OUTPUT 1



-  DC 0-10V
-  DC 0-20mA
-  DC 0-5V
-  DC 4-20mA

Appendix C

Hardware Definition Code

The Hardware Definition Code is used to represent the hardware installed (input type, Output 1 type, Output 2 type and Output 3 type); this must be compatible with the hardware actually installed. It can be accessed, with the instrument in Program mode, by simultaneously depressing the DOWN and SCROLL keys. The displays will show "XXXX" (where X represents any number) in the upper display and "dEFn" in the lower display, where:

the first (left-most) digit is input type:

- 1=RTD/Linear mV
- 2=Thermocouple
- 3=Linear DC mA
- 4=Linear DC V

the second digit is Output 1 type:

- 1=Relay
- 2=SSR
- 3=DC 0-10V
- 4=DC 0-20mA
- 5=DC 0-5V
- 7=DC 4-20mA

the third digit is Output 2 type:

- 0=Output 2 not installed
- 1=Relay (control or alarm)
- 2=SSR (control or alarm)
- 3=DC 0-10V (control only)
- 4=DC 0-20mA (control only)
- 5=DC 0-5V (control only)
- 7=DC 4-20mA (control only)

the fourth digit is Output 3 type:

- 0=Output 3 not installed
- 1=Relay (alarm only)
- 2=SSR (alarm only)
- 3=DC 0-10V (retransmit only)
- 4=DC 0-20mA (retransmit only)

5=DC 0-5V (retransmit only)
7=DC 4-20mA (retransmit only)

The displayed code may be incremented/decremented using the UP/DOWN keys as required. The maximum setting available is 4777. For example, the code for a thermocouple input, DC 4-20mA Output 1 and relay Output 3 would be 2701. When the code is first altered, the code display will flash, until the desired value is displayed and confirmed by pressing the Auto/Manual key.

While the Hardware Definition Code is displayed, depressing the SCROLL key will cause the display to change to:

nonE	or	r485
OPtn		OPtn

Where nonE indicates the absence of the communications option and r485 indicates the presence of the communications option.

NOTE: It is essential that this code is changed whenever there is a change to the instrument's hardware configuration (change of input/output type, alarm/retransmit output added/removed etc.). The instrument's software depends upon this code to ensure that the instrument operates correctly.

To exit from the Hardware Definition Code display, depress the DOWN and SCROLL keys simultaneously.

Appendix D

Input Range Codes

The input ranges available (selectable via the front panel) are:

For Thermocouple Inputs

TYPE	INPUT RANGE	DISPLAYED CODE	TYPE	INPUT RANGE	DISPLAYED CODE
R	0 - 1650°C	1127	K	0 - 760°C	1719
R	32 - 3002°F	1128	K	32 - 1400°F	1720
S	0 - 1649°C	1227	K	0 - 1373°C	1723
S	32 - 3000°F	1228	K	32 - 2503°F	1724
J	0.0 - 205.4°C	1415	L	0.0 - 205.7°C	1815
J	32.0 - 401.7°F	1416	L	32.0 - 402.3°F	1816
J	0 - 450°C	1417	L	0 - 450°C	1817
J	32 - 842°F	1418	L	32 - 842°F	1818
J	0 - 761°C	1419	L	0 - 762°C	1819
J	32 - 1402°F	1420	L	32 - 1404°F	1820
T	-200 - 262°C	1525	B	212 - 3315°F	1934
T	-328 - 504°F	1526	B	100 - 1824°C	1938
T	0.0 - 260.6°C	1541			
T	32.0 - 501.1°F	1542			

For RTD Inputs

Note: Input conditioning jumper JU1 needs to be changed, see Appendix B.

INPUT RANGE	DISPLAYED CODE	INPUT RANGE	DISPLAYED CODE
0 - 600°C	2221	0.0 - 100.9°C	2295
32 - 1112°F	2222	32.0 - 213.6°F	2296
32 - 572°F	2229	-200 - 206°C	2297
-101.0 - 100.0°C	2230	-328 - 403°F	2298
-149.8 - 212.0°F	2231	-101.0 - 300.5°C	7201
0 - 300°C	2251	-149.8 - 572.9°F	7202

For DC Inputs

Note: Input conditioning jumper JU1 needs to be changed, see Appendix B. Also, the Hardware Definition Code for the input type must also be changed, see Appendix C.

INPUT RANGE	DISPLAYED CODE	INPUT RANGE	DISPLAYED CODE
0 - 20mA	3413	0 - 5V	4445
4-20mA	3414	1 - 5V	4434
0 - 50mV	4443	0 - 10V	4446
10 - 50mV	4499	2 - 10V	4450

Appendix E

Specifications

INPUT SPECIFICATIONS

General

Input Sample Rate:	Four per second
Input Resolution:	14 bits approximately
Input Impedance:	Greater than 100M ohm resistive (except for DC mA and V inputs)
Isolation:	Universal input isolated from all outputs SSR at 240 VAC.

Thermocouple

Types:	R, S, J, T, K, L and B
Calibration:	Complies with BS4937, NBS125 and IEC584.
Sensor Break Protection:	Break detected within 2 seconds. Control outputs set to OFF (0% power); alarms operate as if the process variable has gone over-range.

RTD and DC mV

Type and Connection:	Three-wire Pt100
Calibration:	Complies with BS1904 and DIN43760.
Lead Compensation:	Automatic
Sensor Break Protection:	Break detected within 2 seconds. Control outputs set to OFF (0% power); alarms operate as if the process variable has gone under-range.

DC mA and DC V

Scale Range Maximum:	-1999 to 9999
Scale Range Minimum:	-1999 to 9999
Minimum Span:	1 display LSD
Sensor Break Protection:	Applicable to 4-20mA, 1-5V, and 2-10V ranges only. Break detected within 2 seconds. Control outputs set to OFF (0% power); alarms operate as if the process variable has gone under-range.

Output Specifications

Output 1

General

Types Available: Relay (standard), SSR and DC as options.

Relay

Contact Type: SPDT
Rating: 2A resistive at 120/240V AC
Lifetime: > 500,000 operations at rated voltage/current
Isolation: Inherent

SSR Drive/TTL

Drive Capability: SSR > 4.2V DC into 1K ohm minimum
Isolation: Not isolated from input or other SSR outputs.

DC

Resolution: Eight bits in 250mS (10 bits in 1 second typical, >10 bits in >1 second typical).
Update Rate: Every control algorithm execution
Ranges: 0-20mA, 4-20mA, 0-10V, and 0-5V*
Load Impedance: 0-20mA: 500 ohm maximum
4-20mA: 500 ohm maximum
0-10V: 500 ohm minimum
0-5V: 500 minimum
Isolation: Isolated from all other inputs and outputs.

*Changes between V and mA ranges also require JU movement.

OUTPUT 2

General

Types Available: Relay, SSR and DC

Relay

Contact Type: SPDT
Rating: 2A resistive at 120/240V AC
Lifetime: > 500,000 operations at rated voltage/current
Isolation: Isolated from all other inputs and outputs

SSR Drive/TTL

Drive Capability: SSR>4.3V DC into 250 ohm minimum
Isolation: Not isolated from input or other SSR outputs

DC

Resolution: Eight bits in 250mS (10 bits in 1 second typical, >10 bits in >1 second typical)
Update Rate: Every control algorithm execution
Ranges: 0-10mA, 4-20mA, 0-10V, and 0-5V*
Load Impedance: 0-20mA: 500 ohm maximum
4-20mA: 500 ohm maximum
0-10V: 500 ohm minimum
0-5V: 500 ohm minimum
Isolation: Isolated from all other inputs and outputs

*Changes between V and mA ranges also require JU movement.

OUTPUT 3

General

Types Available: Relay, SSR and DC linear (retransmit only)

Relay

Contact Type: SPDT
Rating: 2A resistive at 120/240V AC
Lifetime: > 500,000 operations at rated voltage/current
Isolation: Inherent

SSR Drive/TTL

Drive Capability: SSR>4.3V DC into 250 ohm minimum
Isolation: Not isolated from input or other SSR outputs

DC

Resolution: Eight bits in 250mS (10 bits in 1 second typical, >10 bits in >1 second typical).
Update Rate: Every control algorithm execution
Ranges: 0-20mA, 4-20mA, 0-10V, and 0-5V*
Load Impedance: 0-20mA: 500 ohm maximum
4-20mA: 500 ohm maximum
0-10V: 500 ohm minimum
0-5V: 500 ohm minimum

Isolation: Isolated from all other inputs and outputs.

* Changes between V and mA ranges also require JU movement.

CONTROL SPECIFICATIONS

Auto Tune Types: Pre-Tune and Auto-Tune
Proportional Bands: 0 (OFF), 0.5% - 999.9% of input span @ 0.1% increments
Auto Reset: 1s-99min 59s and OFF
Rate: 0 (OFF) - 99min 59s
Manual Reset: Adjustable in the range 0-100% of output power (single output) or -100% to +100% of output power (dual output)
Deadband/Overlap: -20% to +20% of proportional band 1 + proportional band 2
ON/OFF Hysteresis: 0.1% to 10.0% of input span (control relay only)
Alarm relay hysteresis is fixed at 2°C/F
Auto/Manual Control: User-selectable with "bumpless" transfer into and out of Manual control.
Cycle Times: Selectable for 0.5s to 512s in binary steps
Setpoint Range: Limited by Setpoint Upper and Setpoint Lower limits
Setpoint Ramp: Ramp rate selectable 1-9999 LSDs per hour and infinite. Number displayed is decimal point aligned with selected range.

Alarms

Maximum Number: Two "soft" alarms plus Loop Alarm
Maximum # Outputs: Up to 2 outputs can be used for alarm purposes
Combination Alarms: Logical OR or AND of alrms to an individual hardware output is available.

PERFORMANCE

Reference Conditions

Ambient Temperature: 20°C ± 2°C
Relative Humidity: 60-70%
Supply Voltage: 90-264V AC 50Hz ±1%
Source Resistance: <10 ohm for T/C input
Lead Resistance: <0.1 ohm/lead balanced (Pt100)
Common Mode
Rejection: >120dB at 50/60Hz giving negligible effect at up to 264V 50/60Hz

Series Mode

Rejection: >500% of span (at 50/60Hz) causes negligible effect

DC Linear Inputs

Measurement

Accuracy: $\pm 0.25\%$ of span ± 1 LSD

Thermocouple Inputs

Measurement

Accuracy: $\pm 0.25\%$ of span ± 1 LSD

Note: Reduced performance with Type B T/C between 100-600 °C (212 - 1112 °F)

Linearization

Accuracy: Better than $\pm 0.2^{\circ}\text{C}$ any point, any 0.1°C range ($\pm 0.05^{\circ}\text{C}$ typical). Better than $\pm 0.5^{\circ}\text{C}$ any point, any 1°C range.

Cold Junction

Compensation: Better than $\pm 0.7^{\circ}\text{C}$

RTD Inputs

Measurement

Accuracy: $\pm 0.25\%$ of span ± 1 LSD

Linearization

Accuracy: Better than $\pm 0.2^{\circ}\text{C}$ any point, any 0.1°C range ($\pm 0.05^{\circ}\text{C}$ typical). Better than $\pm 0.5^{\circ}\text{C}$ any point, any 1°C range.

OPERATING CONDITIONS

Ambient Operating Temperature: 0° to 55°C

Ambient Storage Storage: -20° to 80°C

Relative Humidity: 20% - 95% non-condensing

Supply Voltage: 90 - 264VAC 50/60Hz (standard)

Source Resistance: 1000Ω maximum (thermocouple)

Lead Resistance: 50Ω per lead maximum balanced (Pt100)

PHYSICAL

Dimensions: 1/8 DIN front panel (48mm x 96mm) 4.33 inches deep

Mounting: Plug-in with panel mounting fixing strap.
Panel cut-out 45mm x 45mm.

Terminals: Screw type (combination head)

Weight: 8 ounces maximum

Front Panel Sealing: NEMA4 type / IP65

Appendix F

Order Matrix

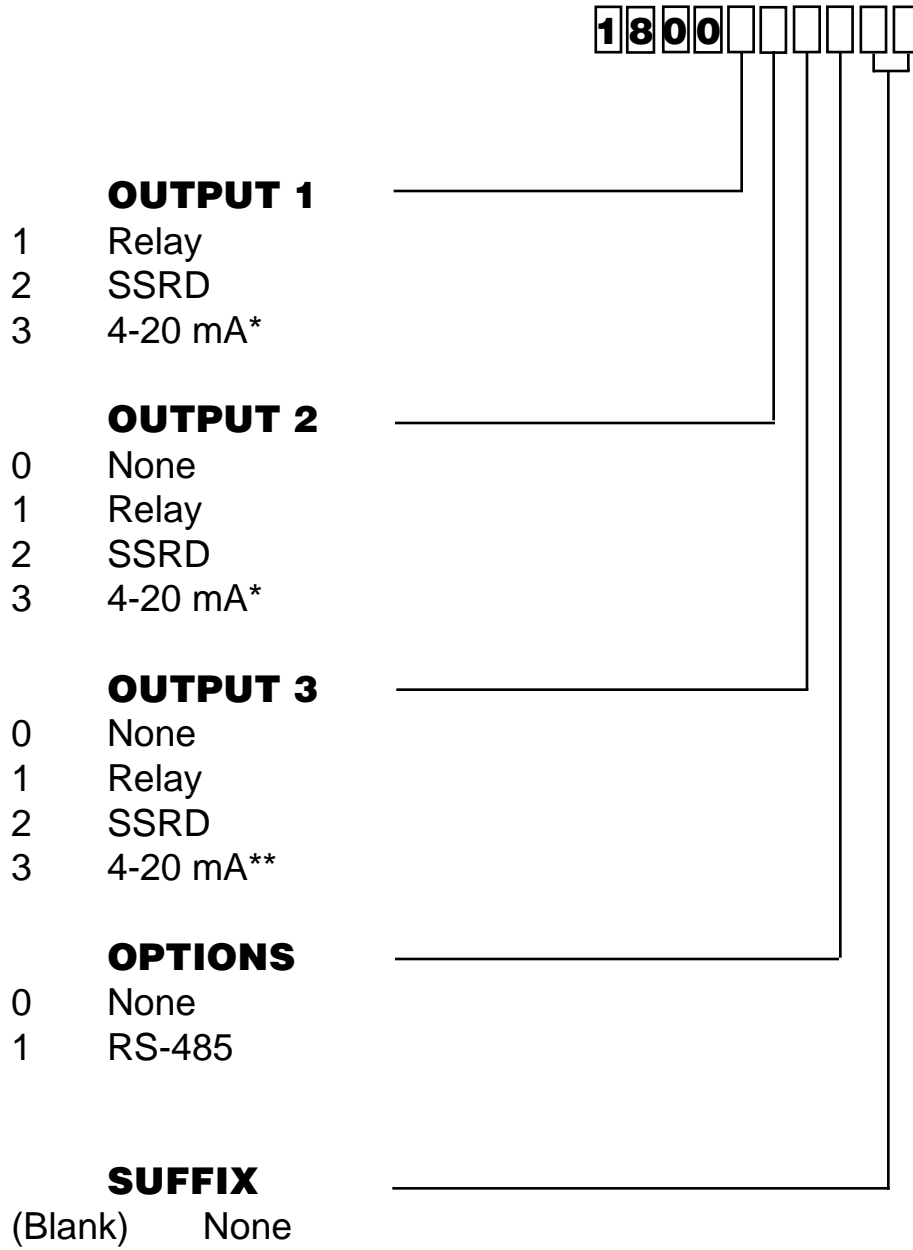

*For control output only
 ** For retransmission only

Warranty and Return Statement

These products are sold by The Partlow Corporation (Partlow) under the warranties set forth in the following paragraphs. Such warranties are extended only with respect to a purchase of these products, as new merchandise, directly from Partlow or from a Partlow distributor, representative or reseller, and are extended only to the first buyer thereof who purchases them other than for the purpose of resale.

Warranty

These products are warranted to be free from functional defects in materials and workmanship at the time the products leave the Partlow factory and to conform at that time to the specifications set forth in the relevant Partlow instruction manual or manuals, sheet or sheets, for such products for a period of three years.

THERE ARE NO EXPRESSED OR IMPLIED WARRANTIES WHICH EXTEND BEYOND THE WARRANTIES HEREIN AND ABOVE SET FORTH. PARTLOW MAKES NO WARRANTY OF MERCHANTABILITY OR FITNESS FOR A PARTICULAR PURPOSE WITH RESPECT TO THE PRODUCTS.

Limitations

Partlow shall not be liable for any incidental damages, consequential damages, special damages, or any other damages, costs or expenses excepting only the cost or expense of repair or replacement as described above.

Products must be installed and maintained in accordance with Partlow instructions. Users are responsible for the suitability of the products to their application. There is no warranty against damage resulting from corrosion, misapplication, improper specifications or other operating condition beyond our control. Claims against carriers for damage in transit must be filed by the buyer.

This warranty is void if the purchaser uses non-factory approved replacement parts and supplies or if the purchaser attempts to repair the product themselves or through a third party without Partlow authorization.

Returns

Partlow's sole and exclusive obligation and buyer's sole and exclusive remedy under the above warranty is limited to repairing or replacing (at Partlow's option), free of charge, the products which are reported in writing to Partlow at its main office indicated below.

Partlow is to be advised of return requests during normal business hours and such returns are to include a statement of the observed deficiency. The buyer shall pre-pay shipping charges for products returned and Partlow or its representative shall pay for the return of the products to the buyer.

Approved returns should be sent to: PARTLOW CORPORATION
2 CAMPION ROAD
NEW HARTFORD, NY 13413 USA