



AirHeat Burners

Model AH

Version 2

Patent US 6,394,795 B2

Main Specifications

PARAMETER	SPECIFICATIONS	
	Imperial	Metric
Maximum input: at neutral conditions and $\Delta p \text{ Air}^{1)}$ = 1.0" w.c. (2.5mbar)	1,000,000 Btu/hr/LF	961 kW/m
Minimum input: at neutral conditions and $\Delta p \text{ Air}^{1)}$ = 1.0" w.c. (2.5mbar)	25,000 Btu/hr/LF	24.5 kW/m
Main gas inlet pressure • natural gas pressure at gas inlet (Tap "B")	8.7 "w.c.	22 mbar
High fire flame length ²⁾ • measured from the burner outlet.	43 in	1100 mm
Upstream temperature limit	Packaged blower ³⁾ Remote Blower	-40 to +104 °F -40 to +400 °C
Downstream temperature limit	w/ 321 SS Wings w/ 330 SS Wings	1300 °F 1500 °F
Flame monitoring	Flame rod or UV scanner	
Ignition	Direct spark ignition ⁴⁾ Spark ignited pilot ⁵⁾	
Fuel	Natural Gas, Propane or Butane. ⁶⁾ For any other mixed gas, contact Eclipse Combustion.	

1) $\Delta p \text{ Air}$ is measured between tap "A" and tap "C" (see page 5 for tap locations).

2) Based on typical parallel process air flow. If mounted in a cross flow, flame will be shorter.

3) Based on blower motor limitations.

4) Direct spark ignition is possible up to 60% of maximum rated input.

5) Pilot input ~25,000 Btu/hr (7.3 kW).

6) See Design Guide 135 for more information about typical combustion and properties.

- All information is based on laboratory testing in neutral (0.0" w.c.) chamber. Different chamber conditions will affect the data.
- All inputs based upon gross calorific values and standard conditions: 1 atmosphere, 70 °F (21 °C).
- Blower motor service factors greater than 1.0 may be required when firing into negative chamber pressure applications. For specific application questions, contact your Eclipse Combustion representative.
- Eclipse reserves the right to change the construction and/or configuration of our products

Performance Graphs

Control & Operational Zone

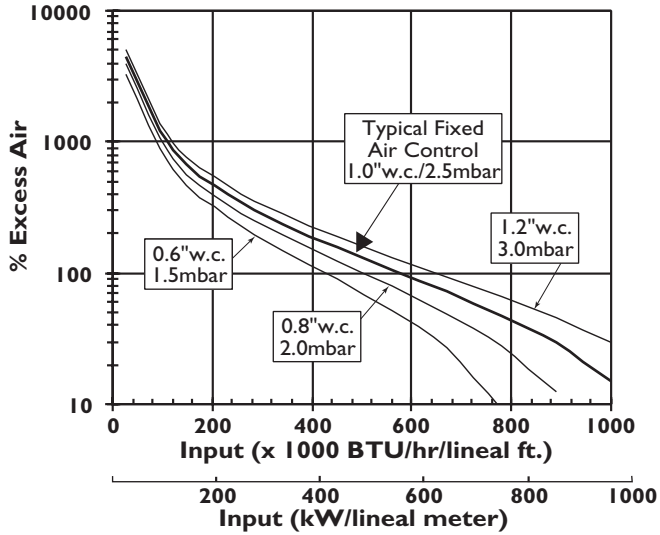

Notes on Control & Operational Zone

This graph shows the amount of excess air through the burner at various ΔP air settings and as a function of the input. At lower excess air levels, complete combustion will require sufficient O_2 in the process air flow.

Contact your local Eclipse Combustion representative with details of your application.

NO_x and CO Emission Data (at 3 vol. % O₂ - dry)

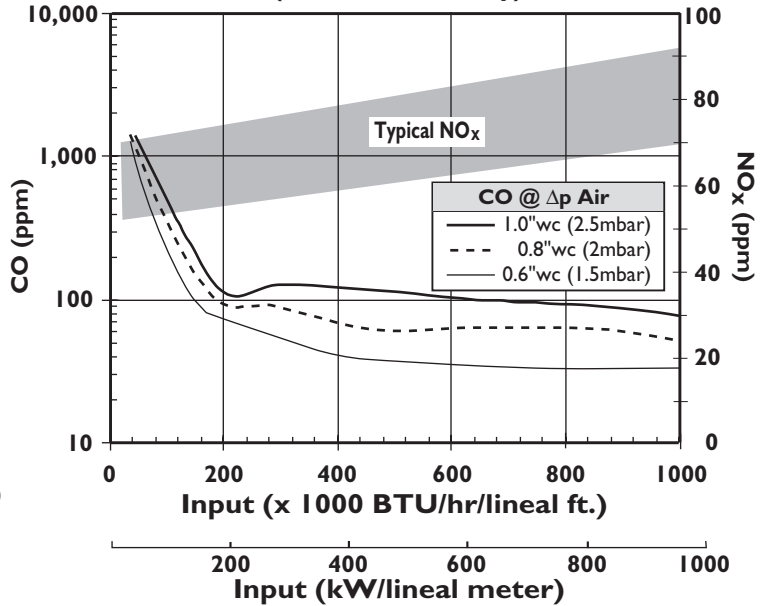

Notes on emission data

NO_x and CO emission data is given for:

- Ambient combustion air ~70 °F (20 °C)
- Minimal process air velocity
- Neutral chamber pressure
- Natural Gas

Emissions are influenced by:

- Chamber conditions
- Fuel type
- Firing rate

CO emission is largely influenced by chamber conditions. Contact your local Eclipse Combustion representative for an estimate of CO emission on your application.

Fuel Δp vs. Input

(Measured between Taps "B" and "C")

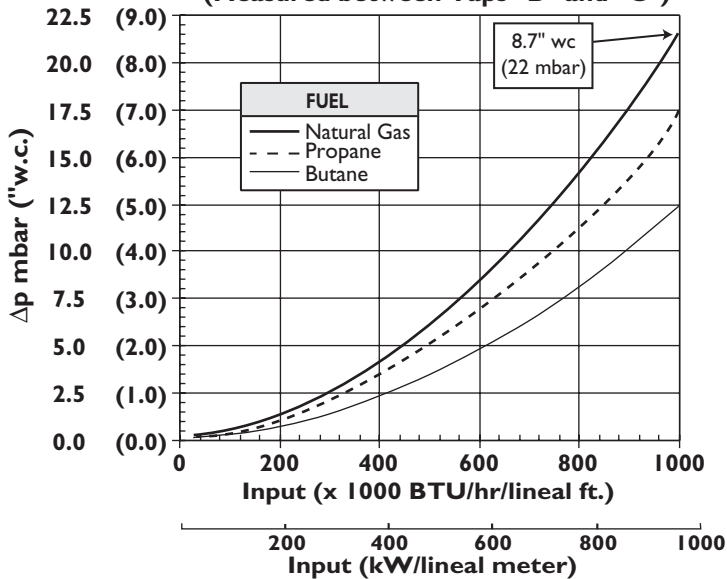

Burner Flame Length

(Measured from the Burner Outlet)

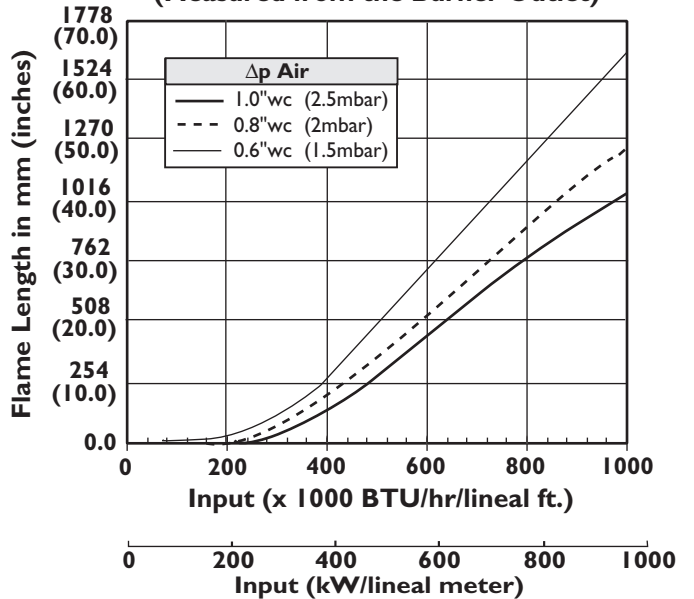

Process Flow Considerations

Parallel Process Flow

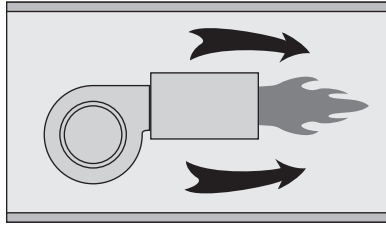

In Duct

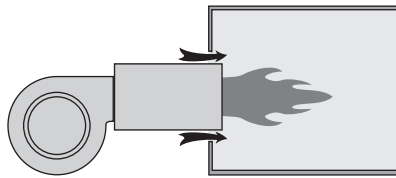

Slot - Fired

Min./Max. Velocity: 500 to 6000 fpm
2.5 to 31 m/s

Optimum Velocity: 1000 to 4000 fpm
5 to 20 m/s

Perpendicular Process Flow

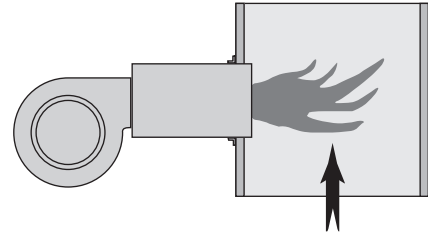

Sealed or Slot Fired

Min./Max. Velocity: 500 to 1200 fpm
2.5 to 6 m/s

Dimensions & Specifications Inches (mm)

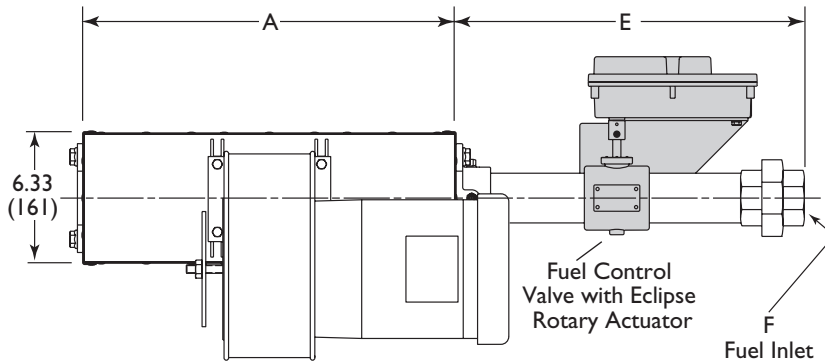

NOTE: All views indicate right hand piping.
Left hand piping is available. See Price List 135

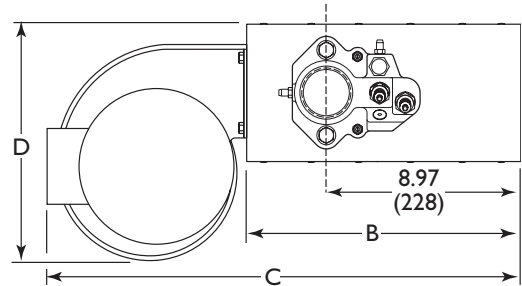

Burner Model	Max. Input MM Btu/hr	Inches									Pipe Thread			Cross Sect. Area in ²	Approx Ship Wt lb
		A	B	60 Hz Blower		50 Hz Blower		E			F				
				C	D	C	D	Nat. Gas	Propane	Butane	Nat. Gas	Propane	Butane		
AH0050	0.5	6.10	12.72	21.42	10.91	21.89	13.62	16.06	16.06	16.06	1	1	1	39	42
AH0100	1.0	12.01	12.72	21.42	10.91	21.89	13.62	16.65	16.06	16.06	1-1/2	1	1	76	49
AH0150	1.5	17.91	12.72	21.42	10.91	21.89	13.62	16.65	16.65	16.06	1-1/2	1-1/2	1	114	57
AH0200	2.0	23.82	12.72	23.35	14.80	21.14	13.74	16.65	16.65	16.65	1-1/2	1-1/2	1-1/2	151	77
AH0250	2.5	29.72	12.72	23.35	14.80	21.14	13.74	16.65	16.65	16.65	1-1/2	1-1/2	1-1/2	188	85
AH0300	3.0	35.63	12.72	23.35	14.80	21.65	15.24	16.73	16.65	16.65	2	1-1/2	1-1/2	226	92
AH0350	3.5	41.54	12.72	23.35	14.80	21.65	15.24	16.73	16.65	16.65	2	1-1/2	1-1/2	263	100
AH0400	4.0	47.44	12.72	23.35	14.80	21.65	15.24	16.73	16.73	16.65	2	2	1-1/2	301	107

Burner Model	Max. Input kW	mm									Pipe Thread			Cross Sect. Area cm ²	Approx Ship Wt kg
		A	B	60 Hz Blower		50 Hz Blower		E			F				
				C	D	C	D	Nat. Gas	Propane	Butane	Nat. Gas	Propane	Butane		
AH0050	147	155	323	544	277	556	346	408	408	408	R _C 1.0	R _C 1.0	R _C 1.0	250	19
AH0100	293	305	323	544	277	556	346	423	408	408	R _C 1.5	R _C 1.0	R _C 1.0	491	22
AH0150	440	455	323	544	277	556	346	423	423	408	R _C 1.5	R _C 1.5	R _C 1.0	733	26
AH0200	586	605	323	593	376	537	349	423	423	423	R _C 1.5	R _C 1.5	R _C 1.5	974	35
AH0250	733	755	323	593	376	537	349	423	423	423	R _C 1.5	R _C 1.5	R _C 1.5	1216	39
AH0300	879	905	323	593	376	550	387	425	423	423	R _C 2.0	R _C 1.5	R _C 1.5	1457	42
AH0350	1026	1055	323	593	376	550	387	425	423	423	R _C 2.0	R _C 1.5	R _C 1.5	1699	45
AH0400	1172	1205	323	593	376	550	387	425	425	423	R _C 2.0	R _C 2.0	R _C 1.5	1940	49

Dimensions & Specifications (Continued)

Duct Mounting

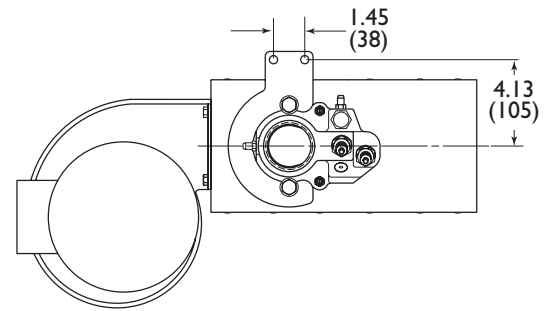
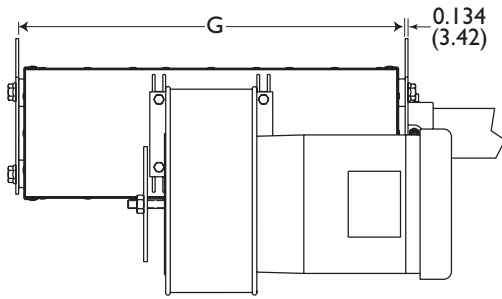

Slot Firing

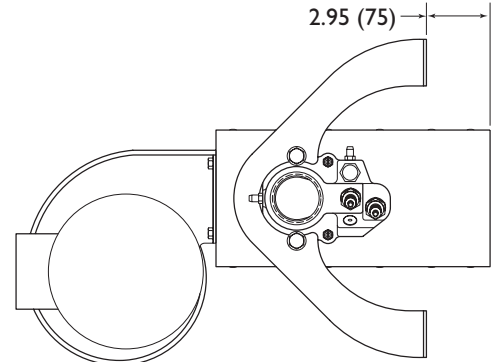
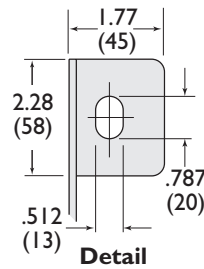
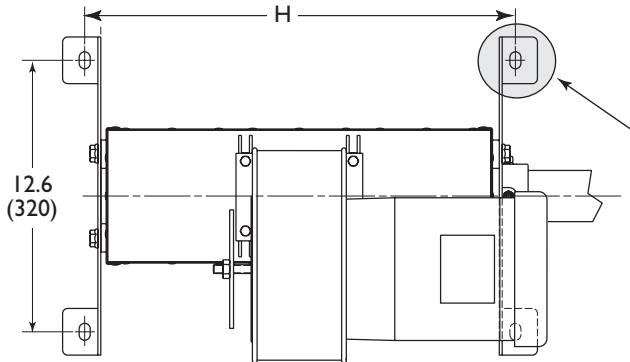

Continuous Mounting

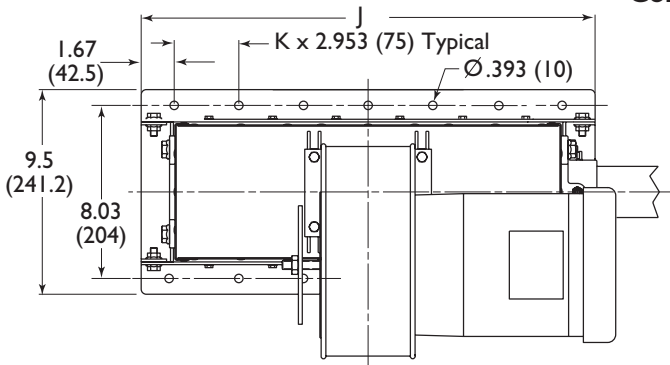

Configurator Flange Option "C" 2.95 (75)
Configurator Flange Option "F" 4.13 (105)

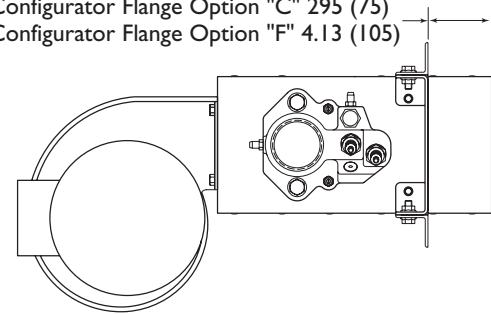

Continuous Mounting 6" Insertion

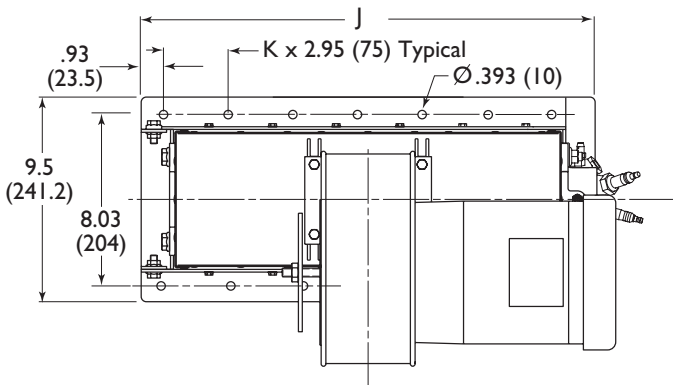

Configurator Flange Option "G" 6.00 (152.4)

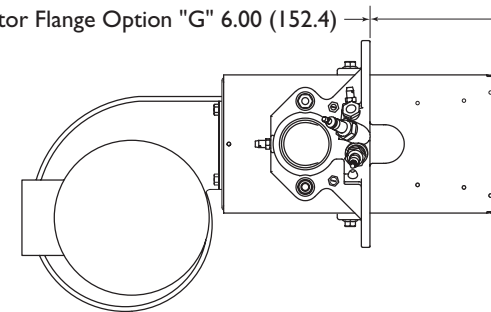

Burner Model	mm				Inches			
	G	H	J	K	G	H	J	K
AH0050	169.7	207.7	235	2	6.68	8.18	9.25	2
AH0100	319.7	357.7	385	4	12.59	14.08	15.16	4
AH0150	469.7	507.7	535	6	18.49	19.99	21.06	6
AH0200	619.7	657.7	685	8	24.40	25.89	26.97	8
AH0250	769.7	807.7	835	10	30.30	31.80	32.87	10
AH0300	919.7	957.7	985	12	36.21	37.70	38.78	12
AH0350	1069.7	1107.7	1135	14	42.11	43.61	44.69	14
AH0400	1219.7	1257.7	1285	16	48.02	49.52	50.59	16

Dimensions & Specifications (Continued)

Combustion Air Inlet

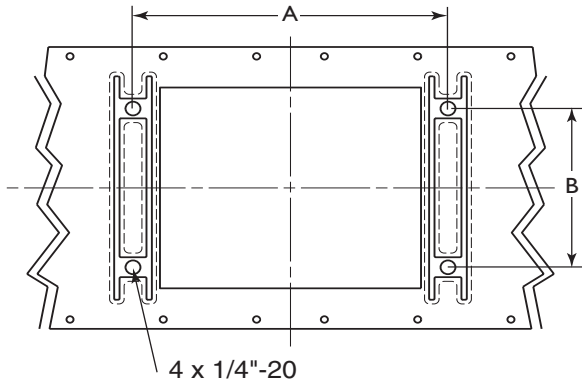

Burner Model	Dimensions			
	mm		Inches	
	A	B	A	B
AH0050	127.0	82.3	5.00	3.24
AH0100	127.0	82.3	5.00	3.24
AH0150	127.0	82.3	5.00	3.24
AH0200	185.7	101.6	7.31	4.00
AH0250	185.7	101.6	7.31	4.00
AH0300	185.7	101.6	7.31	4.00
AH0350	185.7	101.6	7.31	4.00
AH0400	185.7	101.6	7.31	4.00

End Plates

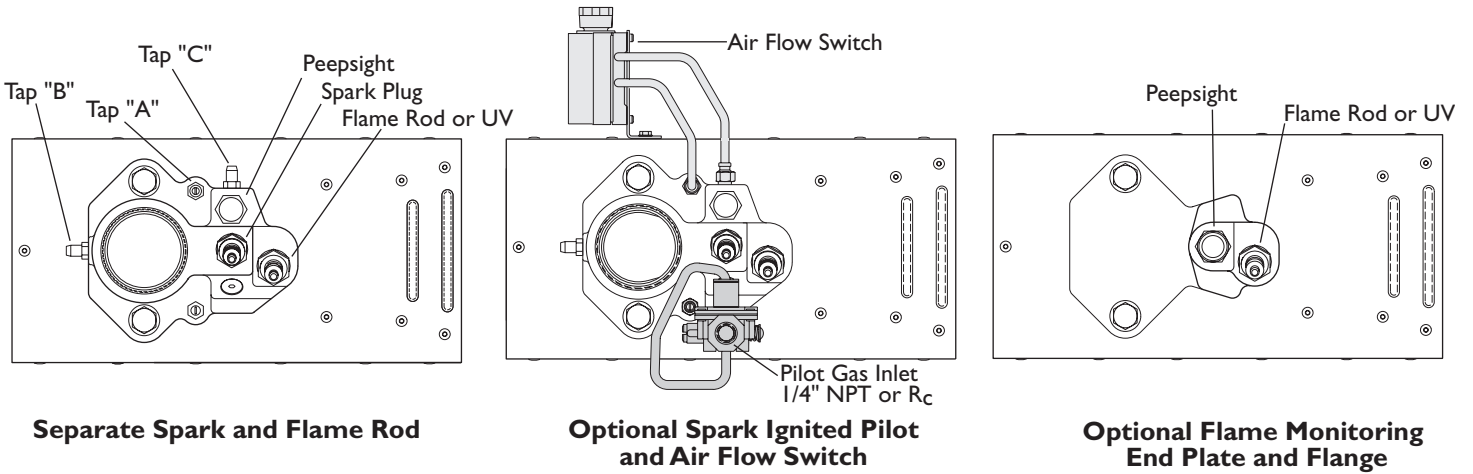

Continuous Mounting 6" Insertion

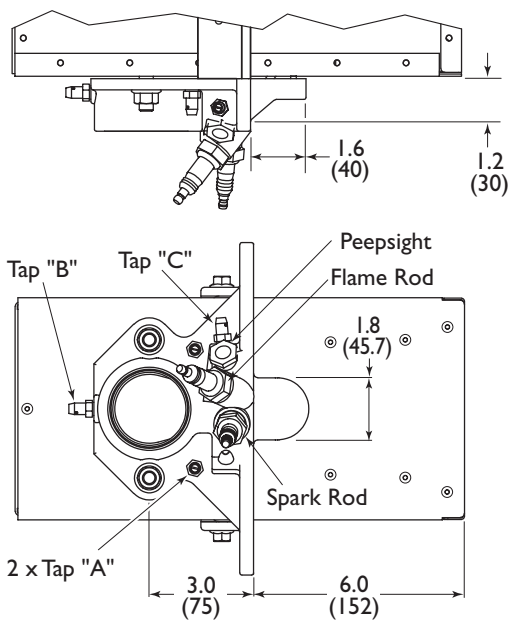

Recommended Oven Wall Cut-Out with 6" Insertion Flange

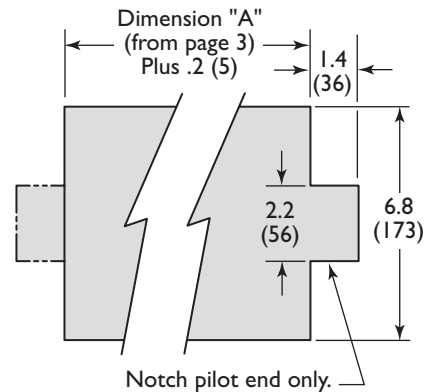

Dimensions & Specifications (Continued)

Combustion Air Blowers

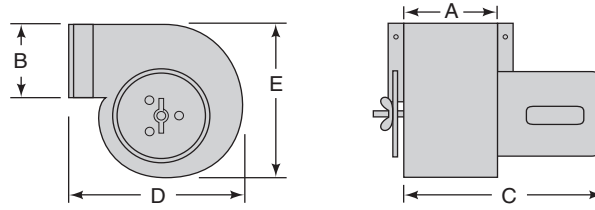

60 Hz Blowers

Use With Burner Cat. No.	Blower Cat. No.	Assy. No.	Rotor No.	Capacity CFH	Static Press "w.c.*	TEFC Motor 230/460/3/60		
						HP	RPM	Part No.
AH0050 thru AH0150	54-54S-1/3	109410	16328	20,000	1.90	1/3	3450	12109**
AH0200 thru AH0300	65-84S-1/3	109241	16706	43,000	1.50	1/3	1750	12110
AH0350 thru AH0400	66-94S-3/4	109243	10539-1	63,000	2.00	3/4	1750	11803

50 Hz Blowers

Use With Burner Cat. No.	Blower Cat. No.	Assy. No.	Capacity CFH	Static Press "w.c.*	Motor			
					kW	RPM	Part No.	Specifications
AH0050 thru AH0100	MN 402	101293	20,000	1.2	0.25	2850	20519	230/440/3/50
AH0150 thru AH0250	MN 502	101294	42,400	1.6	0.37	2850	20520	230/440/3/50
AH0300 thru AH0400	MN 602	101295	74,200	1.6	1.10	2850	20523	230/440/3/50

* Additional capacity at reduced pressure. Static pressure measured at blower outlet using American Fan Association Standards.

** TENV Motor

60 Hz Blowers

Dimensions Inches (mm)	Blower Catalog Number		
	54-564S-1/3	65-84S-1/3	66-94S-3/4 66-94S-1
A	4.00 (102)	6.06 (154)	6.06 (154)
B	4.12 (105)	5.06 (129)	6.31 (160)
C 1/3 HP	12.25 (311)	14.62 (371)	---
C 3/4 HP	---	---	15.50 (394)
D	8.31 (211)	12.93 (329)	15.00 (381)
E	8.62 (219)	13.75 (349)	15.50 (394)
Wt. Lbs. (kg)	6.4 (3)	19.5 (9)	24.0 (11)

Note: Weight does not include motor.

50 Hz Blowers

Dimensions Inches (mm)	Blower Catalog Number		
	MN 402	MN 502	MN 602
A	4.33 (110)	4.33 (110)	5.51 (140)
B	5.12 (130)	6.30 (160)	7.48 (190)
C	11.61 (295)	12.52 (318)	15.15 (385)
D	8.78 (223)	10.75 (273)	13.30 (338)
E	10.63 (270)	12.68 (322)	15.94 (405)
Wt. Lbs. (kg)	6.4 (3)	19.5 (9)	24.0 (11)

Note: Weight does not include motor.

Filters For AirHeat Burners

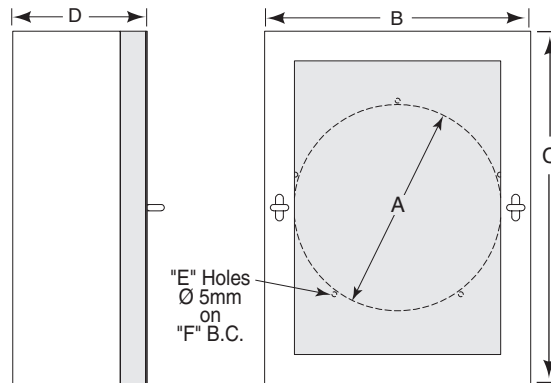

Blower Size	Used on Burner Size	Filter Cat. No.	Filter Assy.No.	Filter Media Assy. No.	Dimensions Inches (mm)					
					A	B	C	D	E	F
54-54 S	50 thru 150	2 AHFS	10009319	10009322	6.0 (150)	8.5 (216)	11.7 (298)	4.3 (110)	4	6.5 (165)
65-84S	200 thru 300	3 AHFS	10009261	10009271	8.0 (208)	10.5 (267)	14.0 (356)	5.3 (135)	5	8.5 (216)
66-94 S	350 thru 400	4 AHFS	10009262	10009272	9.5 (241)	14.0 (356)	20.0 (508)	5.5 (141)	5	10.0 (254)



Eclipse Combustion

www.eclipsenet.com